



Flying Neurons

SuperNeurone

User Manual



Document Status

Document	FLNO_008 version 1.0.EN							
Date	02/04/2025							
Author	Flying Neurons							
Status	Public	<input checked="" type="checkbox"/>	Internal	<input type="checkbox"/>	NDA	<input type="checkbox"/>	Draft	<input type="checkbox"/>

Changes

Version	Date	Description
1.0	02/04/2025	First draft

Content

This document introduces the **SuperNeurone** and explains how to install, configure, and use it.

Table of Contents

1	Declaration of Conformity and Warranty.....	6
2	Warning.....	7
3	Other documents.....	7
4	Overview.....	8
4.1	Features.....	8
4.2	Physical description.....	9
4.2.1	Battery.....	11
4.2.2	Extension Connector.....	12
4.2.3	Antennas.....	15
5	Installation.....	16
5.1	Nomad installation.....	16
5.1.1	Fixation.....	16
5.1.2	Battery charging.....	17
5.1.3	Antenna mounting.....	17
5.1.4	Audio.....	19
5.2	Integrated installation.....	20
5.2.1	Fixation.....	20
5.2.2	Antenna mounting.....	22
5.2.3	Connecting to Power.....	24
5.2.4	Transponder Connection.....	25
5.2.5	Connection to the on-board radio.....	26
5.2.6	Connecting to Traffic Display.....	27
5.2.7	Connecting to an external siren.....	28
5.2.8	Connecting to other devices.....	29
6	SuperNeurone Configuration.....	30
6.1	Installation of SuperNeuroFly.....	30
6.2	Launch of SuperNeuroFly.....	30
6.3	Starting the SuperNeurone.....	31
6.4	Connecting to the SuperNeurone.....	31
6.5	SuperNeurone Configuration.....	32

6.5.1	My Aircraft.....	32
6.5.2	Units.....	33
6.5.3	Watch area.....	33
6.5.4	Mode S Alerts.....	33
6.5.5	Automatic On/Off.....	33
6.5.6	Transponder.....	34
6.5.7	Installation.....	34
6.5.8	Front.....	35
6.5.9	Audio.....	35
6.5.10	Options.....	35
6.5.11	QNH.....	36
6.5.12	Wi-Fi.....	36
6.5.13	My SuperNeurone.....	37
6.5.14	Validate and send the configuration to the SuperNeurone.....	37
7	Configuring third-party instruments or software.....	38
7.1	Transponder.....	38
7.2	Radio.....	38
7.3	Display traffic.....	38
7.3.1	ATD from Air-Avionics.....	38
7.4	Navigation software.....	38
8	Update.....	39
9	Usage.....	40
9.1	Starting and stopping.....	40
9.2	Front panel display.....	40
9.2.1	Directional Indicator.....	41
9.2.2	Risk Level Indicator.....	41
9.2.3	Vertical Indicator.....	41
9.2.4	Special case of "Mode S".....	42
9.2.5	Status Indicators.....	43
9.3	Using SuperNeuroFly to Visualize Traffic and Risk.....	44
9.3.1	Standard operation.....	44
9.3.2	The main screen.....	46
9.3.3	The top banner: The main information.....	46

9.3.4	The bottom banner: the status of connections and peripherals	47
9.3.5	The menu and dialogues	49
9.3.6	The map.....	49
9.3.7	The artificial horizon.....	53
9.3.8	Collision risks, visual and audible alerts.....	56
9.3.9	My SuperNeurone.....	59
9.3.10	App configuration.....	60
9.3.11	Demo / Help.....	64
9.4	Other Display Devices.....	65
9.4.1	Display traffic.....	65
9.4.2	Navigation apps	65
10	Errors and Failures.....	66
10.1	Failures displayed on the front panel	66
10.2	Failures communicated to SuperNeuroSky.....	66
11	Technical specifications.....	66

1 Declaration of Conformity and Warranty

We, Flying Neurons, declare under our sole responsibility that the **SuperNeurone** product is in compliance with the following European standards:

- Radio: EN 300 220-2 (V2.1.2)
- Radio: EN 300 440-2 (V1.2.2)
- E.M.C.: EN 301 489-3 (V1.4.1)
- Electrical safety: EN 60950-1 (2006)
- Health: EN 50371 (2002)



The receiver is class 2 according to EN 300 220-2.

The term "Product" refers to all products manufactured by Flying Neurons and described in this document. Flying Neurons warrants the Product to be free from defects in materials and manufacturing under normal use for a period of 2 years from the date of purchase. The original purchase invoice or receipt, indicating the date of purchase of the Product, constitutes proof of the date of purchase. All software provided with the Product, including firmware, is provided "as is". Flying Neurons does not warrant that the operation of such software will be uninterrupted or error-free, or that such software will meet your requirements. If you make a claim under this Warranty, Flying Neurons may, at its option, repair or replace all or part of the defective Product covered by the Warranty with new or refurbished products or parts. In the event that Flying Neurons chooses to use refurbished parts or products, they will have characteristics or performance equivalent to new products.

All disassembled parts and products replaced under the Warranty become the property of Flying Neurons.

This Warranty does not apply:

- if the Product has been damaged or rendered defective as a result of use of the Product not in accordance with the purpose for which it was designed, including in particular use not in accordance with the user manual provided with the Product, or any other abuse or negligence of the user of the Product.
- if the Product has been modified, including by the use of parts not manufactured or sold by Flying Neurons.
- if the Product has been repaired by someone who is not a member of Flying Neurons or a Flying Neurons authorized service provider.
- in the event of improper transport or packaging when returning the Product to Flying Neurons or a Flying Neurons authorized service provider.
- to loss or damage to software, data or removable storage media. Flying Neurons may choose to replace the Product sent under warranty with a refurbished product of equivalent quality, resulting in the inability for you to have access to the data stored in your original Product.

FLYING NEURONS DISCLAIMS ALL OTHER WARRANTIES, EXPRESS OR IMPLIED, INCLUDING, BUT NOT LIMITED TO, ANY IMPLIED WARRANTIES OF MERCHANTABILITY OR FITNESS FOR A PARTICULAR PURPOSE. IN NO EVENT SHALL FLYING NEURONS BE LIABLE FOR ANY INCIDENTAL, SPECIAL OR CONSEQUENTIAL DAMAGES, INCLUDING, BUT NOT LIMITED TO, LOST PROFITS, LOST DATA OR DOWNTIME, WHETHER THE CLAIM IS BASED IN CONTRACT, TORT OR WARRANTY, WHETHER BASED ON THE USE OR OPERATION OF THE PRODUCT OR ANY SOFTWARE PROVIDED BY FLYING NEURONS WITH THE PRODUCT, EVEN IF FLYING NEURONS HAS BEEN ADVISED OF THE POSSIBILITY OF SUCH DAMAGES.

By making a claim under this Warranty, you acknowledge that the repair and, when available, replacement of the Product in accordance with and within the limits of this Warranty, is your sole and exclusive remedy against Flying Neurons under this Warranty in the event of a defect in the Product covered by this Warranty.

The information contained herein is subject to change without notice. Flying Neurons reserves the right to change or improve its products and to make changes to this content without prior notice. For the latest updates to this document, please visit www.flyingneurons.com.

The trademarks mentioned in this manual are the property of their owners.

2 Warning

The **SuperNeurone** may not detect all surrounding traffic or make errors in its detections.



Therefore, do not make any decisions for your safety or that of third parties, based solely on the information provided by the **SuperNeurone**.

Do not use the **SuperNeurone** until you have read and agreed to the terms of use available at:

<https://www.flyingneurons.com/legal/SuperNeurone.html>



as well as the terms of use of FLARM technology available at:

<https://www.flarm.com/eula>



3 Other documents

Other documents related to the **SuperNeurone** are available on the website <http://www.flyingneurons.com/> :

- Release notes.
- Quickstart nomad installation.
- Quickstart for integrated installation.

4 Overview

4.1 Features



The **SuperNeurone** has been designed to be as interoperable as possible, i.e.:

- Detect as much air traffic as possible.
- Be detected by as many aircraft as possible in the vicinity.
- Analyse and inform the pilot of any risk of collision.

The **SuperNeurone** detects and transmits aircraft positions mainly by radio, which allows reliable operation, anywhere, at any altitude, regardless of any network:

- FLARM transmit and receive.
- ADS-B and S mode transmission and reception (transmission via transponder).
- Transmission and reception Neurone or ADS-L.

In addition, in areas covered by the GSM network, the **SuperNeurone** can connect to the Internet network and see and be seen by Internet platforms (Safesky, OGN, Pilotaware, etc.).

To adapt to each pilot:

- The **SuperNeurone** can be:
 - Nomad.
 - Fully integrated into the dashboard.



- Traffic can be viewed:
 - On the **SuperNeurone** itself.
 - On the **SuperNeuroFly** App.
 - On navigation applications (SDVFR, EasyVFR, Skydemon, Foreflight, ...).
 - On Traffic Display.

4.2 Physical description



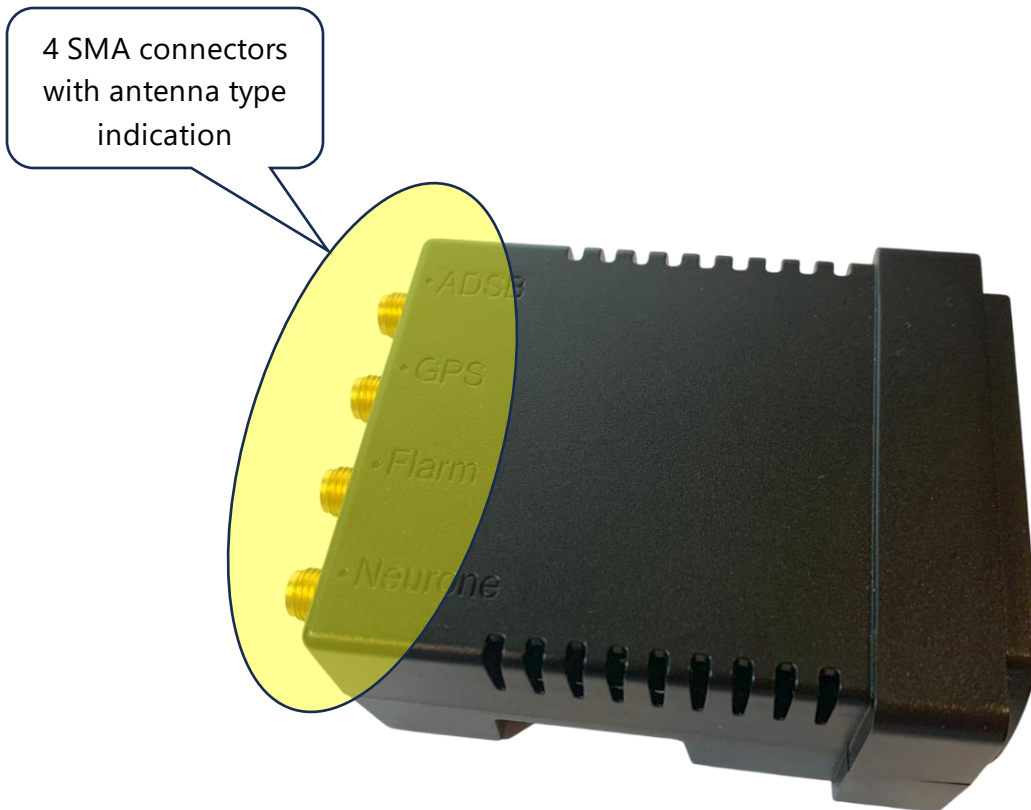
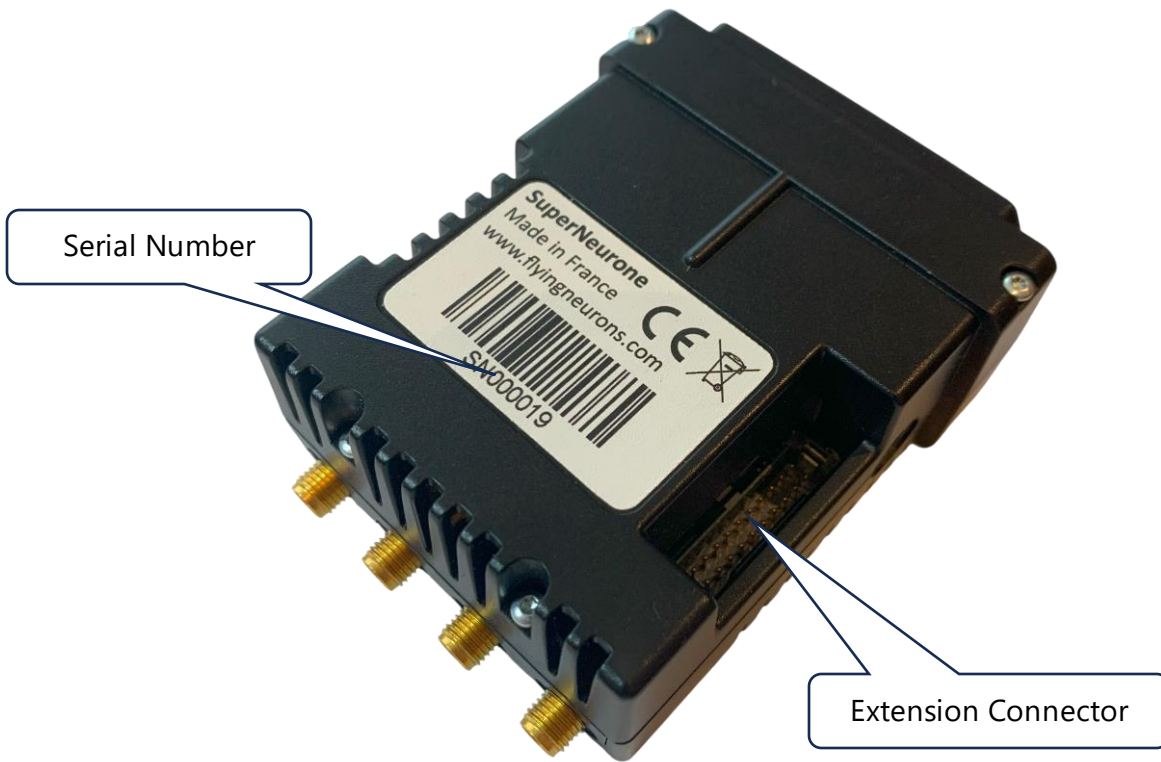

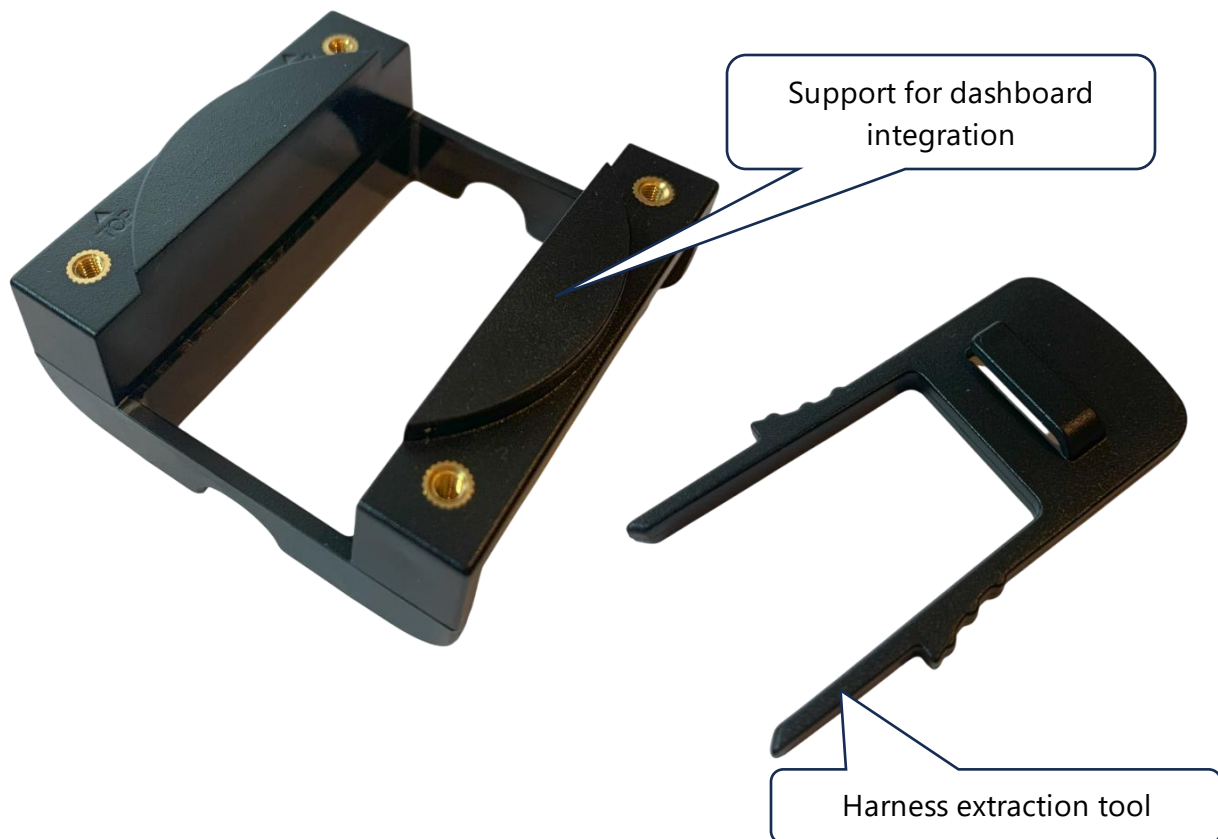

4.2.1 Battery

The **SuperNeurone** has a battery that gives it more than 10 hours of battery life. It can therefore be used with or without a connection to a power supply.

The battery can be recharged:

- By the side jack with a voltage of **5 volts**. Use the USB to Jack cable provided.
- By the 20-pin extension connector using pins 2 and 4. The voltage should be between **6 and 32 volts**.

Both power supplies can be connected simultaneously.

The **SuperNeurone** can be permanently connected to these power supplies.

The charging current does not exceed 1 Ampere. The maximum charging time is 12 hours.



It is imperative to place a fuse or breaker of 1 to 5 Amperes on the power circuit.

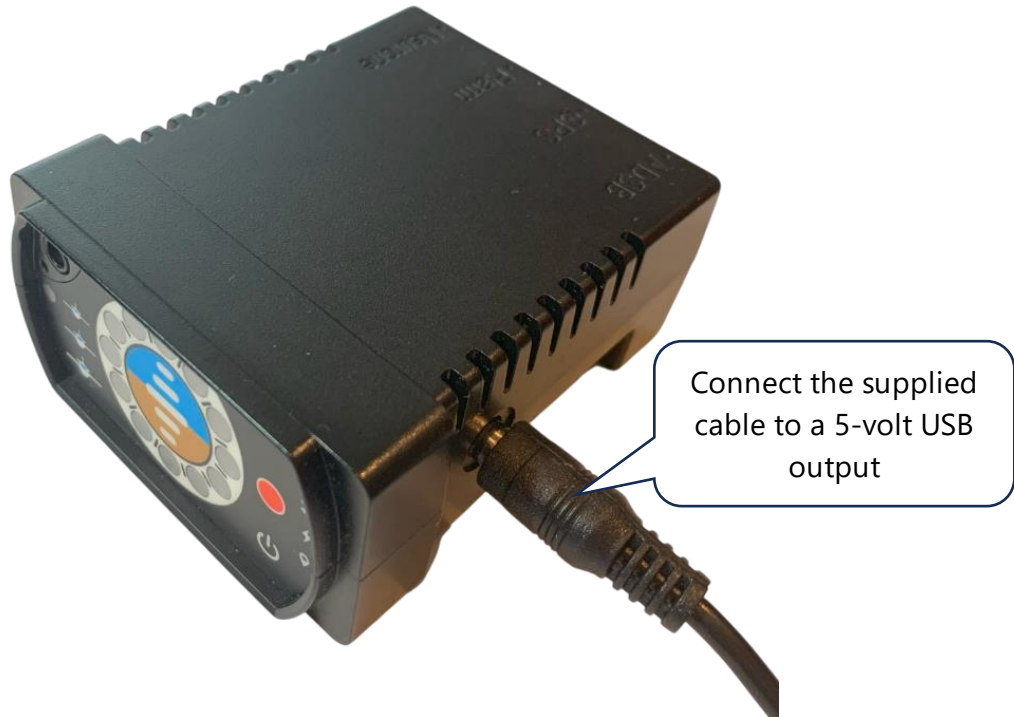

4.2.2 Extension Connector

Make sure the extension connector is oriented correctly by making sure that the 2 notches are positioned as in the photo below.

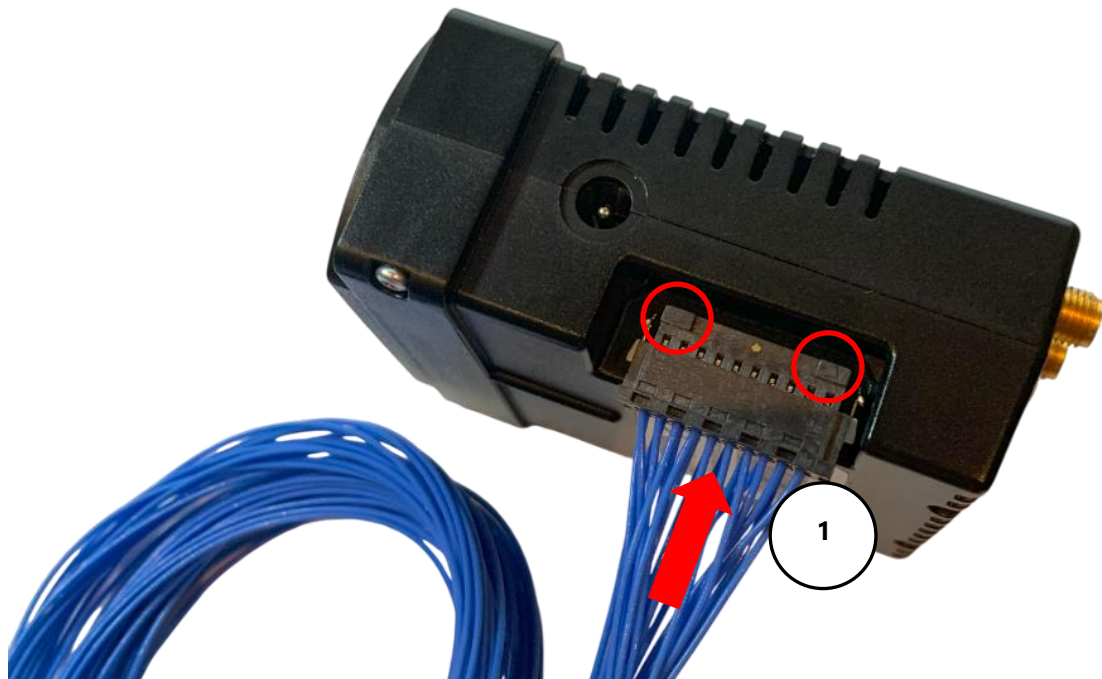

Handle the harness carefully and do not pull a single wire, as this may damage the harness connectors.

Once inserted, the extension connector locks, preventing unintentional disconnection. To remove it, insert the extraction tool as shown in the photo below and then pull on the harness.

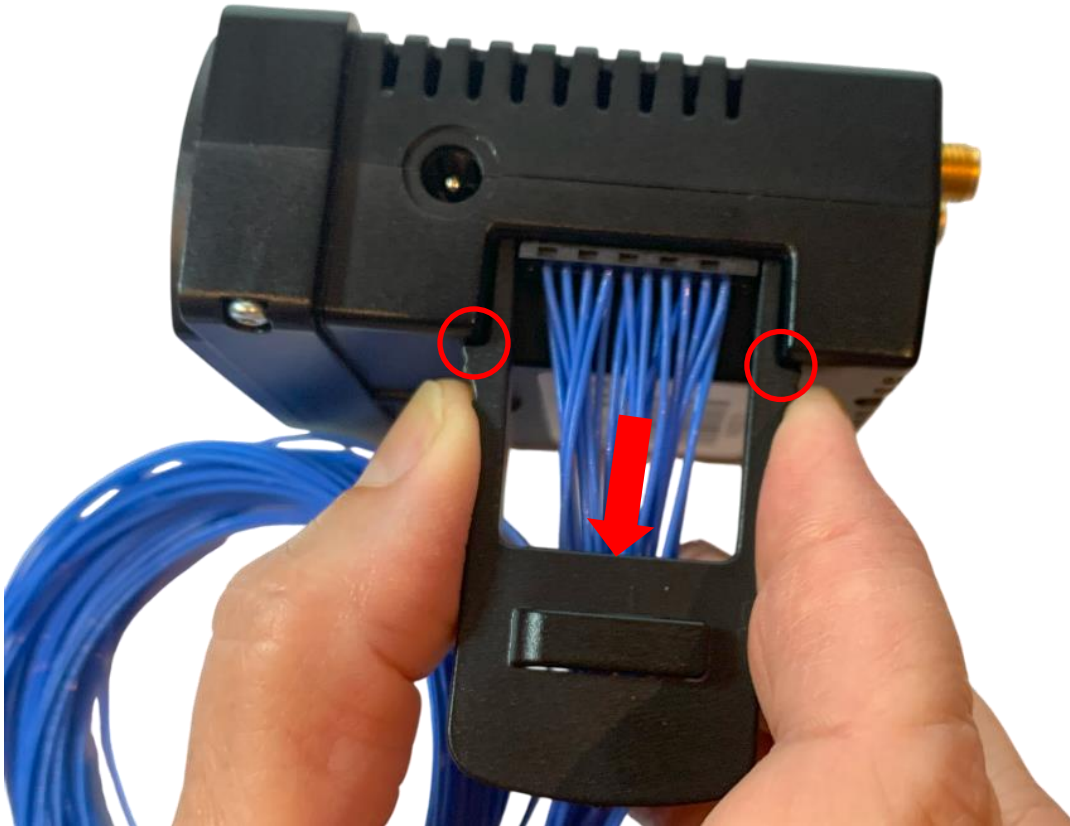

4.2.2.1 Detailed Description of Extension Connector

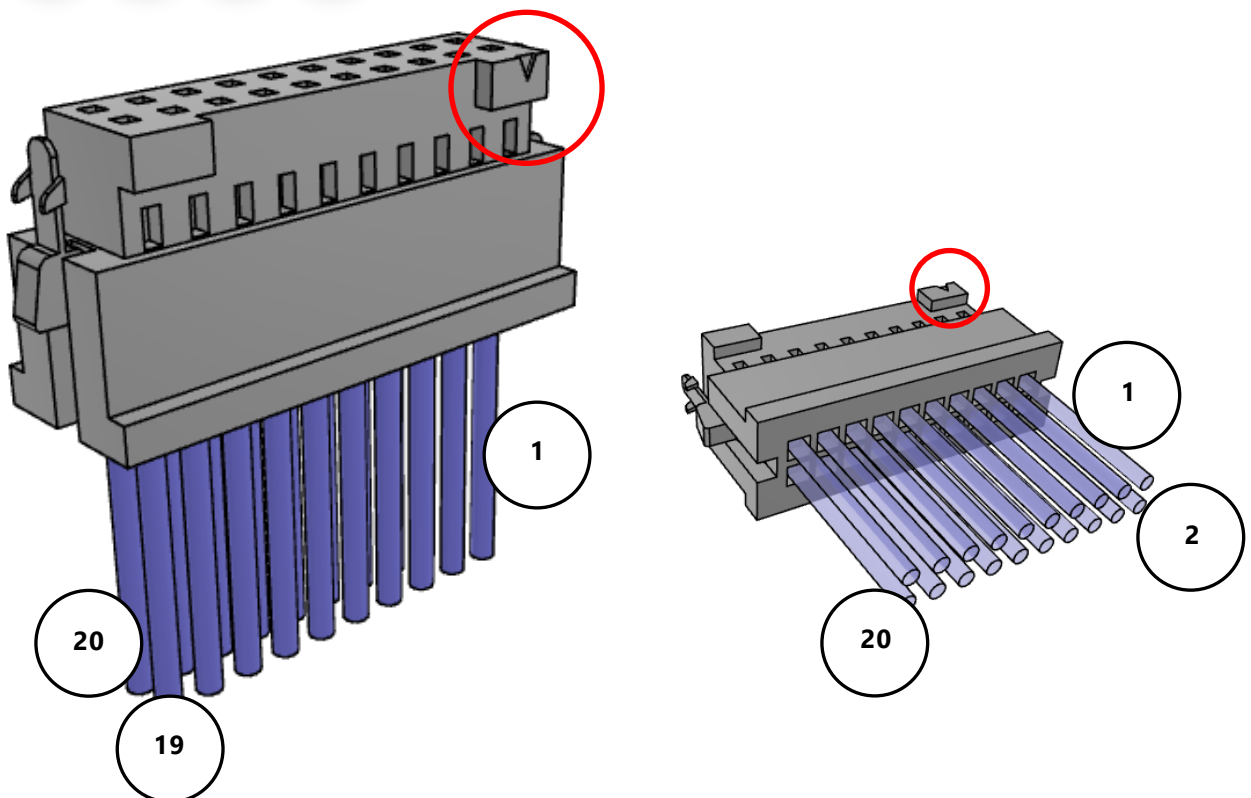

20-pin extension connector Part number SAMTEC S2SDT-10-28-L-40.00-SR	
1: GND RS232_1	2: GND ALIM_6V_32V
3: TX RS232_1	4: ALIM_5V_32V
5: RX RS232_1	6: GPIO_1_EXT
7: GND RS232_2	8: GPIO_2_EXT
9: TX RS232_2	10: GPIO_3_EXT
11: RX RS232_2	12: TXD_TTL
13: GND AUDIO_OUT	14: RESERVED
15: AUDIO_OUT	16: RESERVED
17: GND SIRENE_12V	18: ALIM_EXT
19 : SIRENE_12V_OUT	20: FLASH_EXT

Description of the connector's functions	
RS232_1	RS232 Transponder Connection
RS232_2	RS232 Traffic Display Connection
AUDIO_OUT	To the Aux input of the radio
SIRENE_12V	Optional 12V siren
ALIM_6V_32V	Power supply from 6 to 32V
GPIO_EXT	Optional inputs/outputs
TXD_TTL	Optional TTL output
ALIM_EXT	Optional Output
FLASH_EXT	Optional flash



It is imperative to place a fuse or breaker of 1 to 5 Amperes on the power circuit.

4.2.3 Antennas

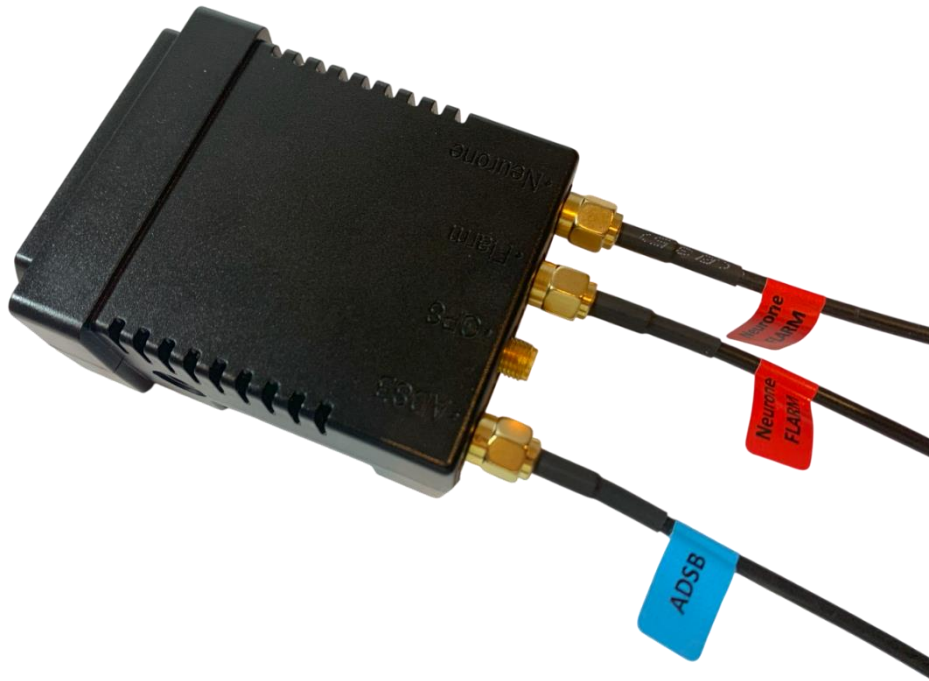

The **SuperNeurone** has 4 SMA antenna connectors:

- Radio antenna for the proprietary long-range protocol "**Neurone**" or the **ADS-L** protocol.
- FLARM antenna for FLARM transmitting and receiving.
- GPS antenna for optional connection to an external GPS antenna.
- ADS-B antenna for receiving ADS-B and Mode S transponders.

Inscriptions on the top of the box indicate the position of the 4 antennas.

A GPS antenna is placed inside the **SuperNeurone**. Use an external GPS antenna only if the **SuperNeurone** does not have a good view of the sky or is covered by a metal or carbon surface.

5 Installation

5.1 Nomad installation

For quick and removable installation, the **SuperNeurone** can simply be placed above the dashboard.



5.1.1 Fixation

For example, use adhesive Velcro or double-sided adhesive.



5.1.2 Battery charging

To recharge the battery, use the included USB to Jack cable and connect it to a USB output that delivers 5 volts. The charging current is less than 1 Ampere.



5.1.3 Antenna mounting

The **SuperNeurone** has 4 SMA-type antenna connectors. The antenna type of each connector is indicated on the top of the **SuperNeurone**.

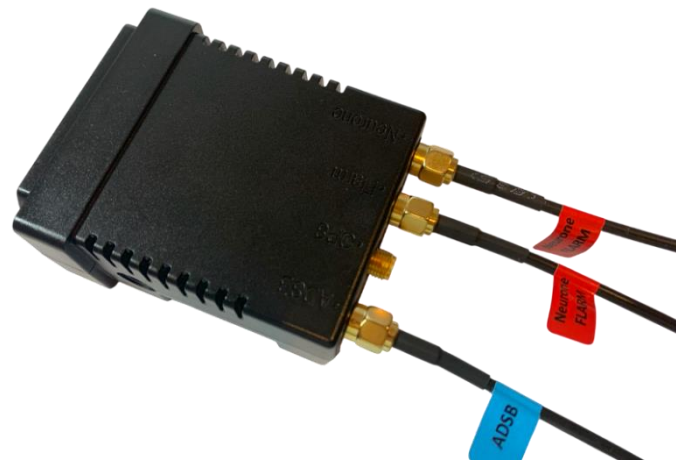

The **SuperNeurone** has an internal GPS antenna. The GPS antenna external to the housing is therefore only necessary if the **SuperNeurone** is covered by a metal or carbon surface. In this case, the external GPS antenna can be fixed above the dashboard.



The 3 antennas (FLARM, ADS-B and Neurone/ADS-L) can be attached to the canopy or above the dashboard. Pay particular attention to the correct positioning of the FLARM antenna as FLARM signals are of low power. Place it away from any metal surfaces or studs.



Take the following precautions:

- Do not start the **SuperNeurone** until you have connected the Neurone/ADS-L and FLARM antennas.
- Hold at least 30 cm between the Neurone/ADS-L and FLARM antennas.
- Maintain at least 1 meter between the ADS-B antenna and the antenna of your transponder.
- Respect the type of antenna written on the top of the **SuperNeurone**.
- The antennas must be placed vertically.
- The antennas should not be attached to metal parts.
- They must have a good view of the sky.

5.1.4 Audio

Headphones can be connected to the front of the **SuperNeurone** via a 3.5 mm audio jack. This allows you to listen to audio alerts.



5.2 Integrated installation

The **SuperNeurone** can be integrated into the dashboard in a standard circular hole with a diameter of 57 mm using the support provided.



The **SuperNeurone** can be connected to the various on-board instruments using the dedicated harness.

This harness exists in 2 forms:

- Harness equipped to connect to instruments via "**SmartConnectors**".
- Unequipped harness ending in free wires.



5.2.1 Fixation

- Place the **SuperNeurone** in its support.
- Insert the harness into the **SuperNeurone**, making sure that it is oriented correctly.
- Slide the assembly into the circular hole with a diameter of 57 mm from the back of the dashboard.
- Secure the assembly using the 4 M3 screws provided.



Handle the harness carefully and do not pull a single wire, as this may damage the harness connectors.

If you want to disconnect the harness from the **SuperNeurone**, insert the extraction tool into the extension connector slot and pull the harness.



5.2.2 Antenna mounting

The **SuperNeurone** has 4 SMA-type antenna connectors. The antenna type of each connector is indicated on the top of the **SuperNeurone**.

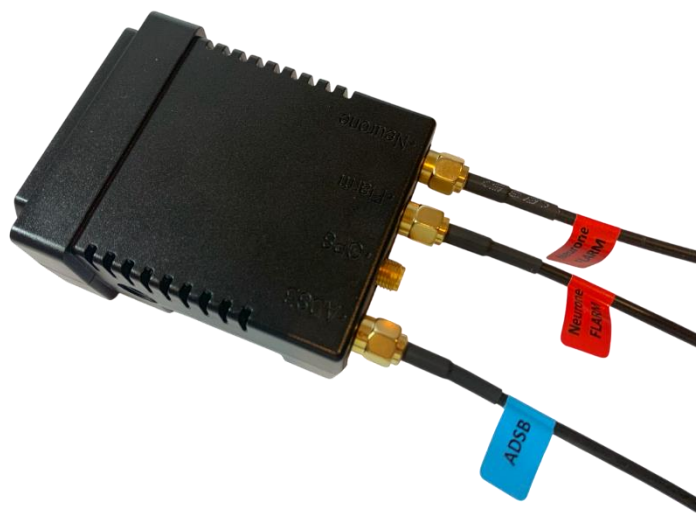

The **SuperNeurone** has an internal GPS antenna. The GPS antenna external to the housing is therefore only necessary if the **SuperNeurone** is covered by a metal or carbon surface. In this case, the external GPS antenna can be fixed above the dashboard.



The choice of the other 3 antennas depends on the structure of the aircraft:

- For aircraft with large metal or carbon parts, it is preferable to use antennas outside the aircraft, especially for the FLARM antenna. This is due to the low power of the FLARM signals.
- For aircraft with large canvas, fiberglass or plastic parts, antennas inside the aircraft may be sufficient.

Antennas inside the aircraft may be attached to the canopy or above the instrument panel.



Most outdoor antennas must be fixed on a "ground plane", i.e. on a metal surface. If the antenna is not attached to a metal surface, you must add a metal disc with a radius of at least 8 cm around the antenna and fix the antenna connector to the center of this disc by electrically connecting it to the disc. This disc can be made from metallized adhesive or bought ready-made.



Take the following precautions:

- Do not start the **SuperNeurone** until you have connected the Neurone/ADS-L and FLARM antennas.
- Hold at least 30 cm between the Neurone/ADS-L and FLARM antennas.
- Maintain at least 1 meter between the ADS-B antenna and the antenna of your transponder.
- Respect the type of antenna written on the top of the **SuperNeurone**.
- The antennas must be placed vertically.
- Indoor antennas should not be attached to metal parts.
- The antennas inside the aircraft must have a good view of the sky.
- Most outdoor antennas must be fixed on a ground plane.

5.2.3 Connecting to Power

If you are using a "**SmartConnector**", insert it between the harness and the output of a breaker or fuse.

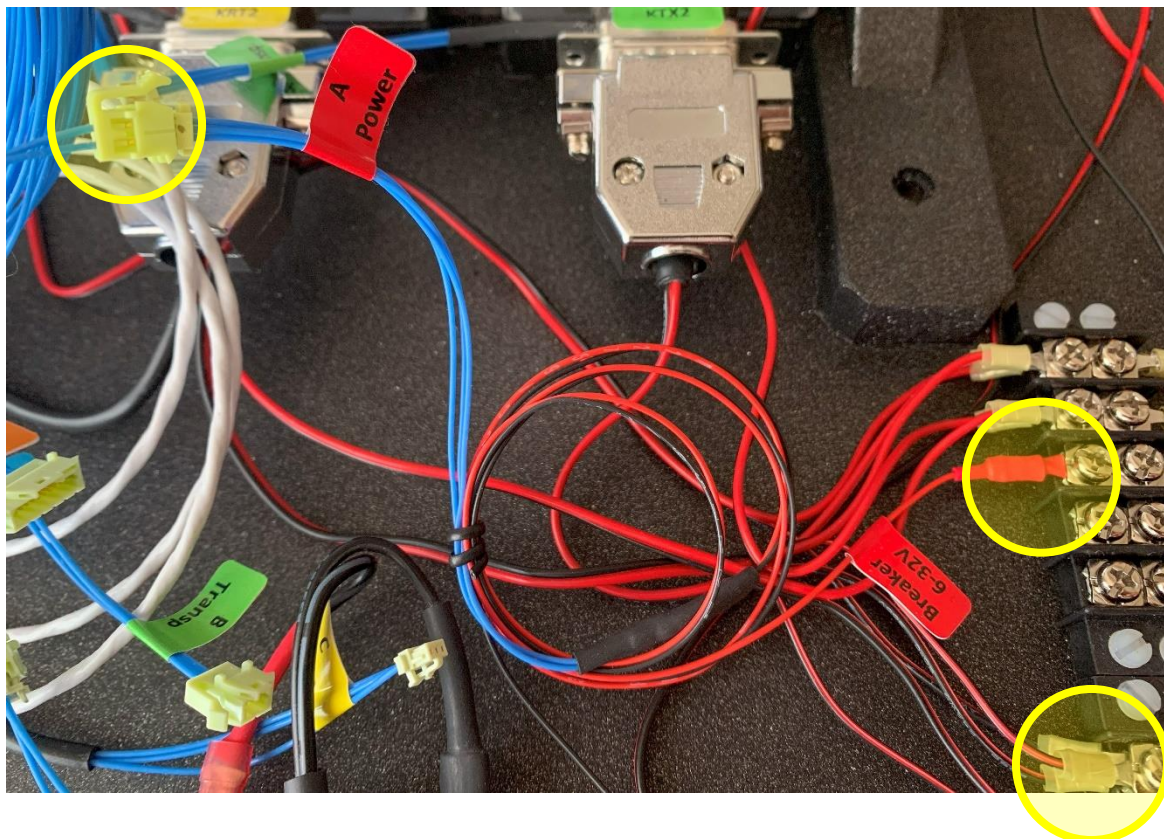

If you are using the harness that is not equipped, connect it to the output of a breaker or fuse according to the following diagram:

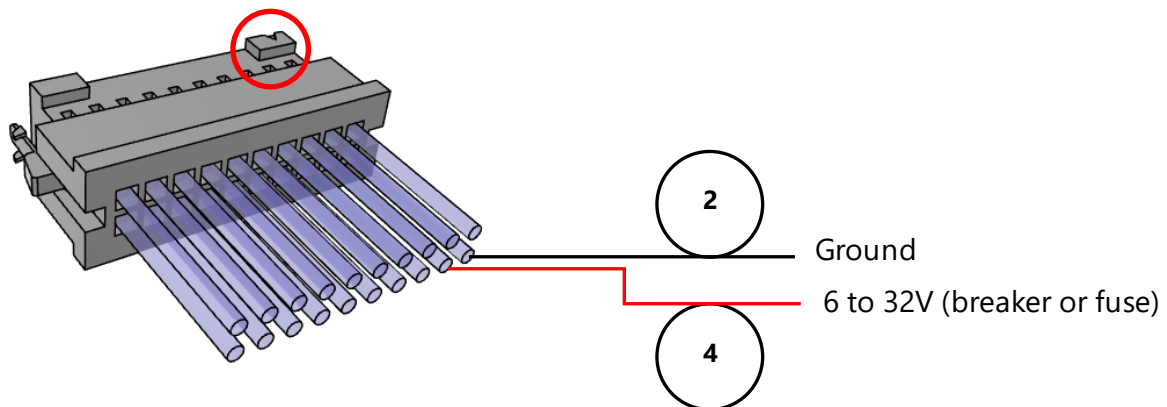

The output voltage of the breaker or fuse should be between 6 and 32 Volts. The **SuperNeurone** charge current does not exceed 1 Ampere, a breaker or fuse between 1 and 5 Amperes is recommended.

5.2.4 Transponder Connection

If you are using a "SmartConnector":

- Disconnect the original harness from the transponder.
- Connect the "SmartConnector" instead.
- Reconnect the original transponder harness to the "SmartConnector".
- Lock the whole thing.
- Connect the **green connector** of the **SuperNeurone** harness to the **green connector** of the "SmartConnector".

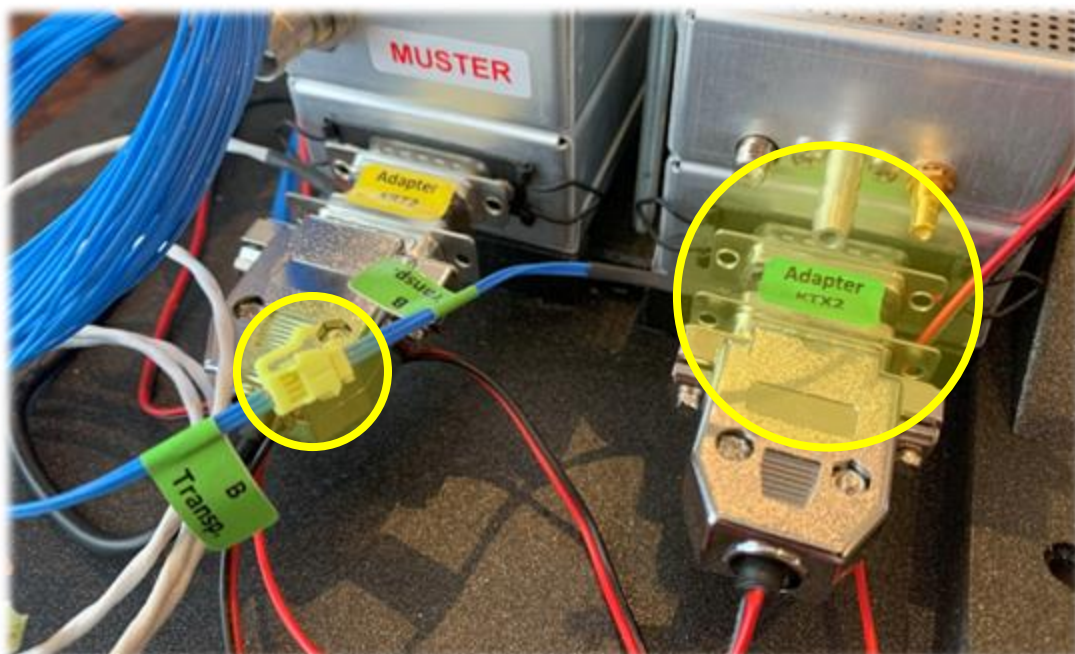

If you are using the unequipped harness, connect it to the transponder according to the following diagram:

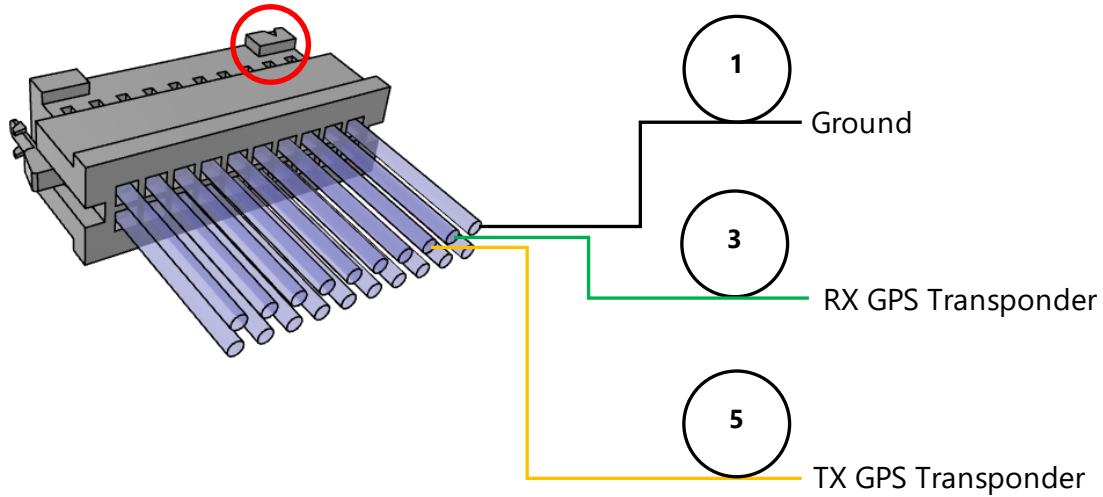

5.2.5 Connection to the on-board radio

If you are using a "SmartConnector":

- Disconnect the original harness from the on-board radio.
- Connect the "SmartConnector" instead.
- Reconnect the original harness of the radio to the "SmartConnector".
- Lock the whole thing.
- Connect the yellow SuperNeurone harness connector to the yellow connector of the "SmartConnector".

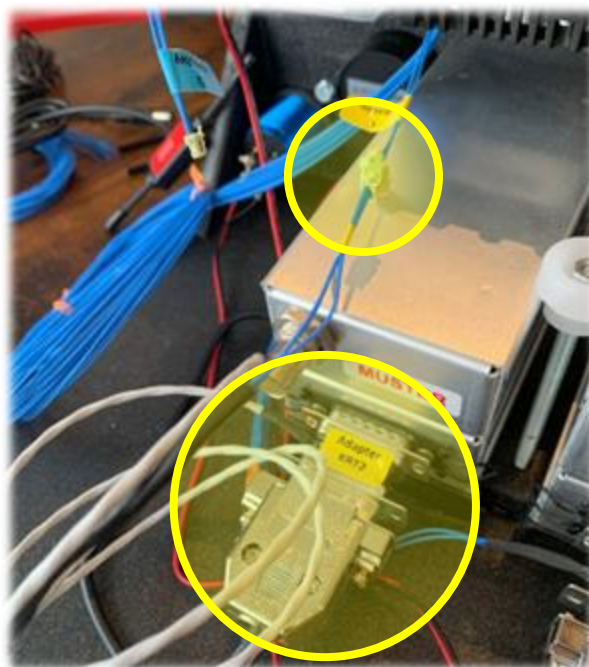

If you are using the harness not equipped, connect it to the radio according to the following diagram:

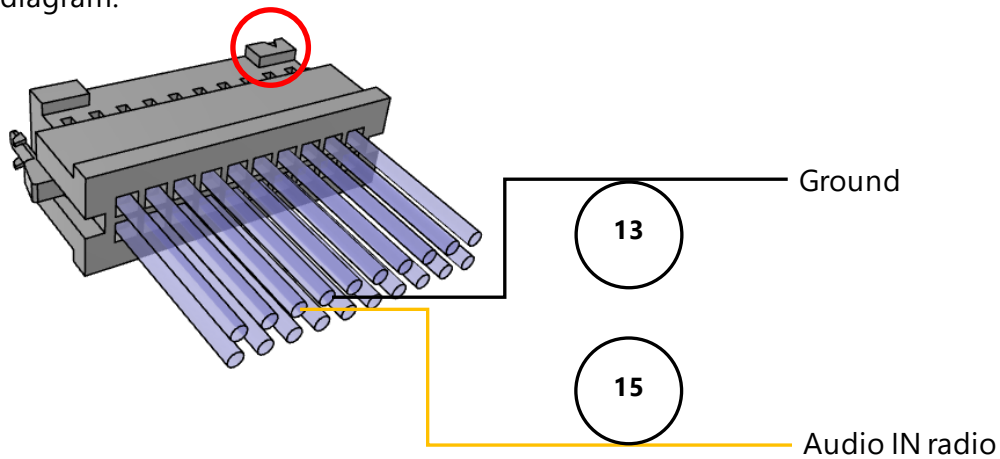

Caution: If you are using shielded audio cable, only connect the cable shield to the on-board radio shield. Do not connect the cable shield from the other end.

5.2.6 Connecting to Traffic Display

5.2.6.1 ATD Air Avionics

If you are using a "SmartConnector":

- Connect the "SmartConnector" to the free connector on the ATD.
- Connect the blue connector of the SuperNeurone harness to the blue connector of the "SmartConnector".

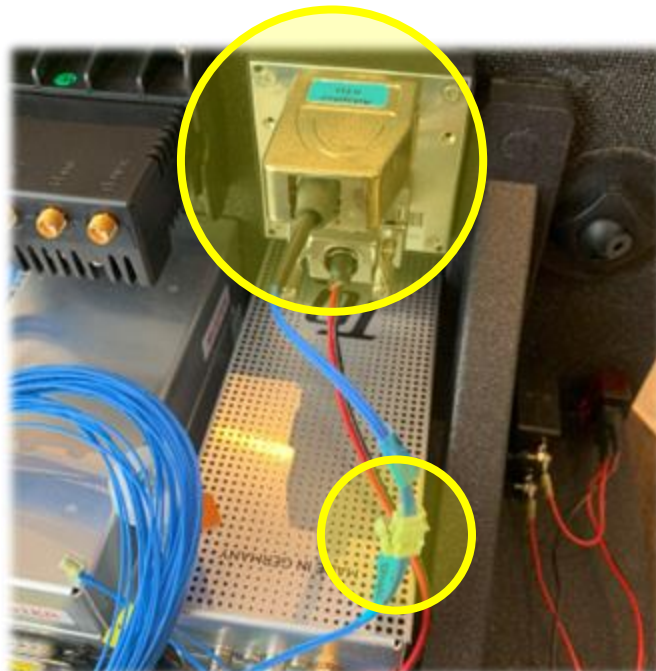

If you are using the harness not equipped, connect it to the ATD according to the following diagram:

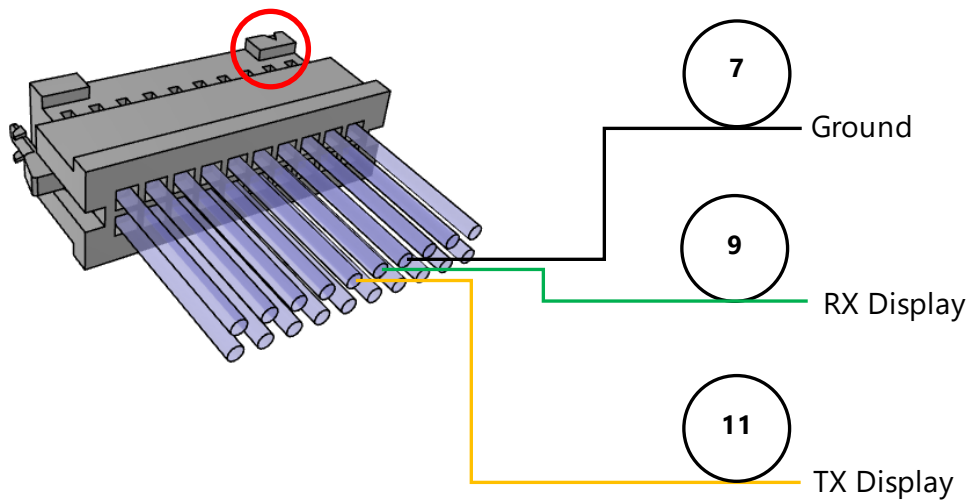

5.2.7 Connecting to an external siren

If you are using a siren with a "SmartConnector" :

- Connect the orange connector of the SuperNeurone harness to the orange connector of the "SmartConnector".



If you are using the harness not equipped, connect it to the siren according to the following diagram:

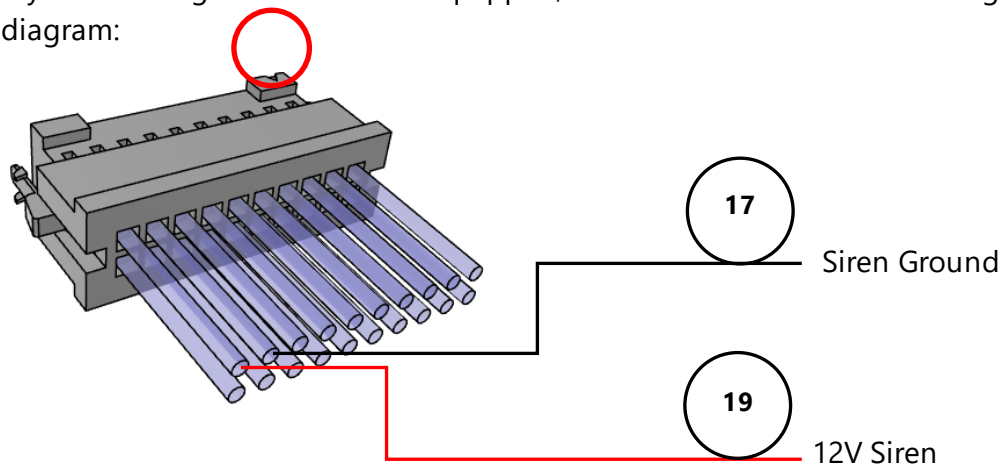

5.2.8 Connecting to other devices

The **SuperNeurone** offers other potential connections. Contact Flying Neurons for this information.

6 SuperNeurone Configuration

Once installed, you need to configure the **SuperNeurone** via the **SuperNeuroFly** App.

6.1 Installation of SuperNeuroFly

The **SuperNeuroFly** App has two purposes:

- Configure and update the **SuperNeurone**.
- Display traffic and collision risks.

Install **SuperNeuroFly** on an iOS or Android smartphone or tablet via the AppStore or GooglePlay:



6.2 Launch of SuperNeuroFly

Launch **SuperNeuroFly** and accept all the permissions requested for its proper functioning.

For example:

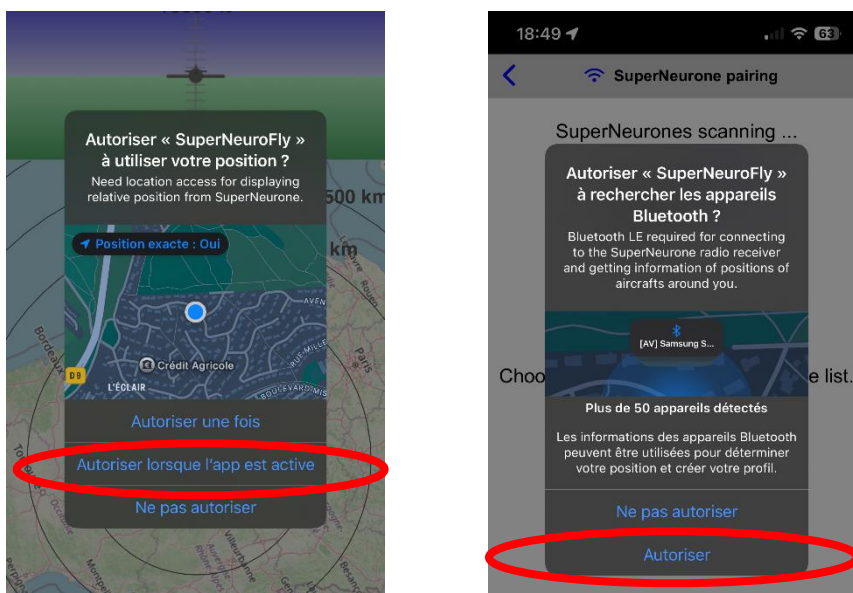

6.3 Starting the SuperNeurone

Press the on/off button for 1 second to start the **SuperNeurone**.

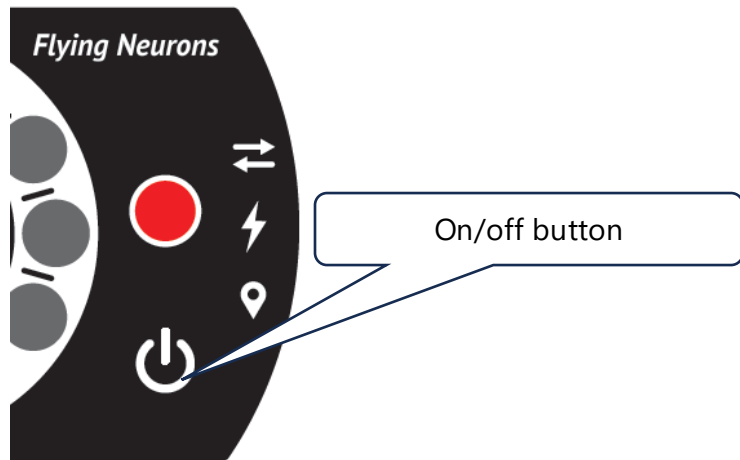

6.4 Connecting to the SuperNeurone

The first time, push the "Start" button. It searches for **SuperNeurones** and click on it in the list to connect:

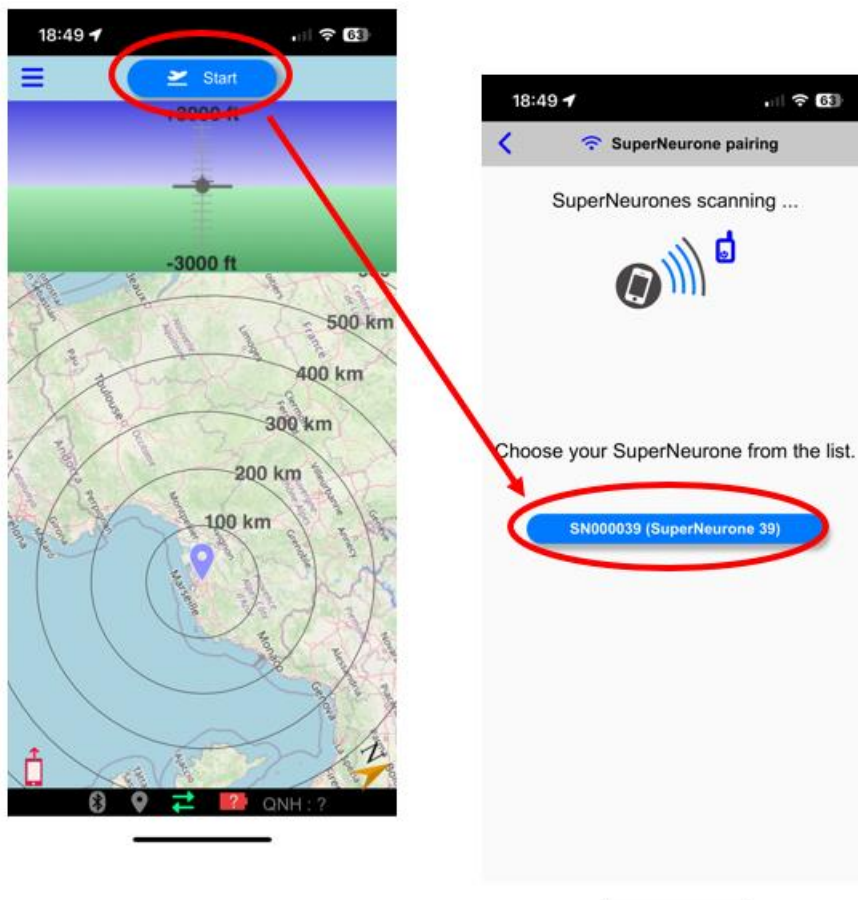

SuperNeuroFly remembers the connection and will automatically reconnect to your **SuperNeurone** with each new launch.

6.5 SuperNeurone Configuration

Go to the "**My SuperNeurone**" menu, click on "**Configure**" to access the **SuperNeurone** configuration dialog:

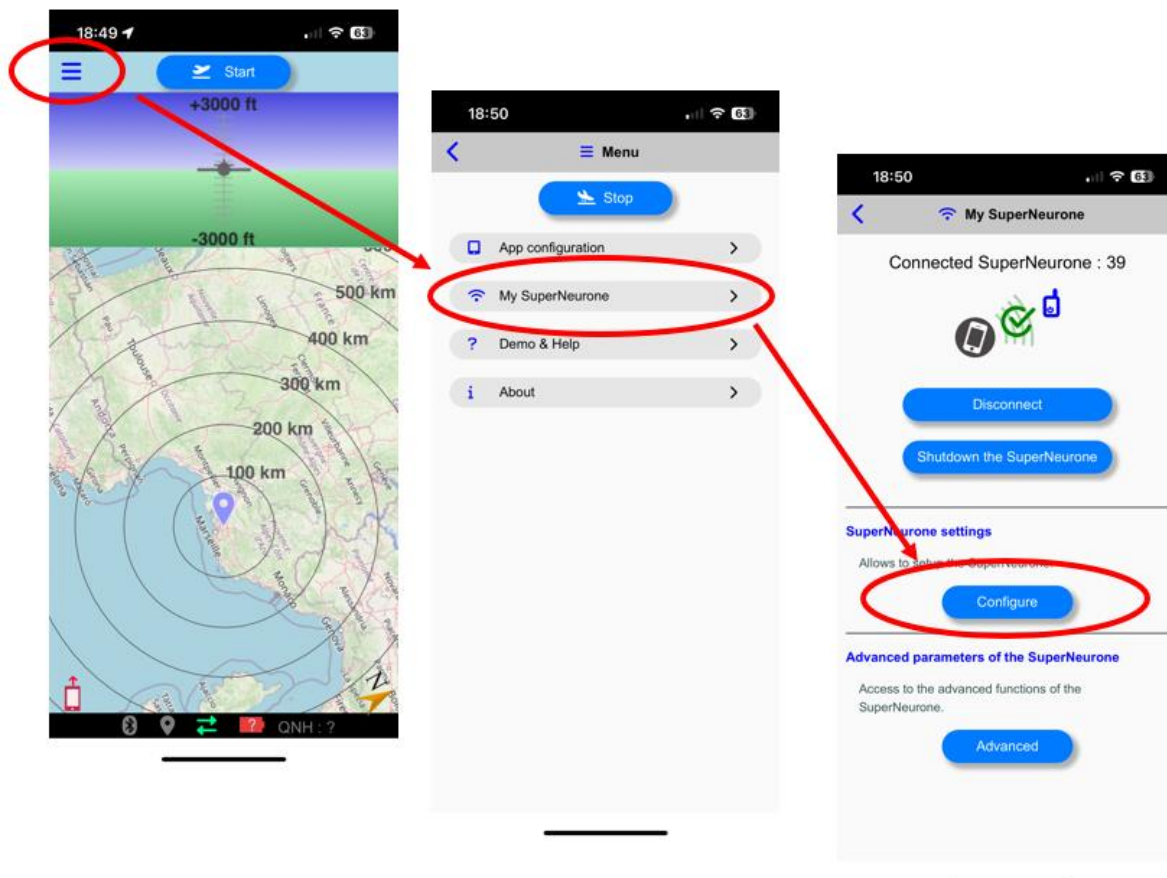

6.5.1 My Aircraft

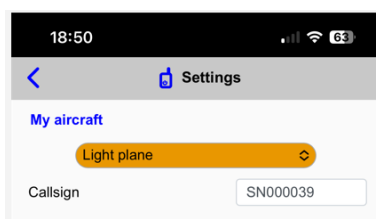

Set your aircraft type for a correct collision risk calculation.

Enter your registration as Callsign to be clearly identified by other devices.

6.5.2 Units

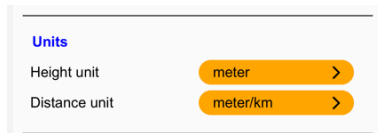

Units

Height unit meter >

Distance unit meter/km >

Define the units used in audio messages and within the **SuperNeuroFly** App.

6.5.3 Watch area



Watch area

Distance max km

Altitude difference max m

Only devices within the distance and altitude window are displayed and used for the risk calculation. It is often interesting to reduce the difference in altitude so as not to see airliners etc ...

6.5.4 Mode S Alerts

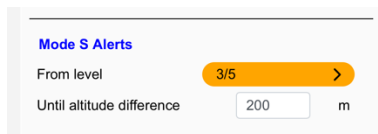

Mode S Alerts

From level 3/5 >

Until altitude difference m

Mode S alerts are generated if 2 conditions are met:

- The signal strength is higher than that provided (on a scale of 5; 5 being the strongest): it allows to alert only for nearby aircraft
- Up to a certain altitude difference: to alert only with aircrafts that fly at your level.

6.5.5 Automatic On/Off



Start / Stop controlled by the charging

Start

Stop

Stopping delay s

If checked, the device starts and/or stops as soon as the power is turned on after a certain period of time for the shutdown.

6.5.6 Transponder

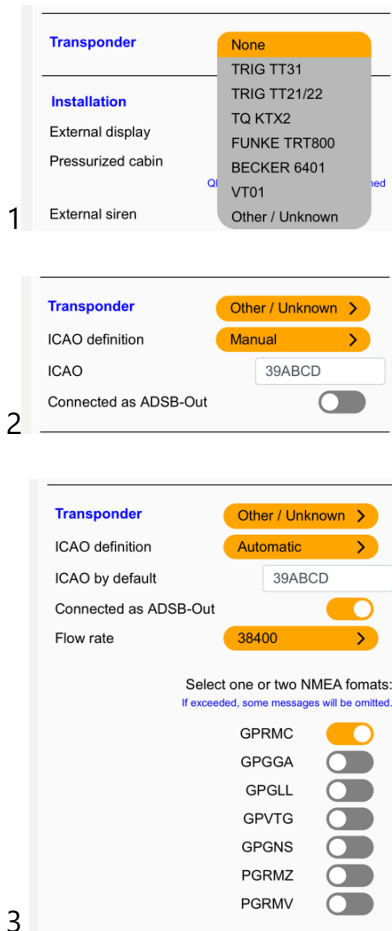

Configure here according to your equipment:

1/ If you don't have a transponder, select "None".

2/ If you have a transponder:

- Choose the type of transponder or "Other/Unknown"
- If you know your ICAO address, stay in Manual mode and specify your address.

- If you don't know your ICAO address, choose the Automatic mode: the **SuperNeurone** will determine your own transponder after a few minutes and update this ICAO address.

3/ If you connect the **SuperNeurone** to your transponder, check the box "connected via ADS-B-Out".

If your transponder is "Other/Unknown", then enter the NMEA connection details as provided in your transponder specifications.

6.5.7 Installation

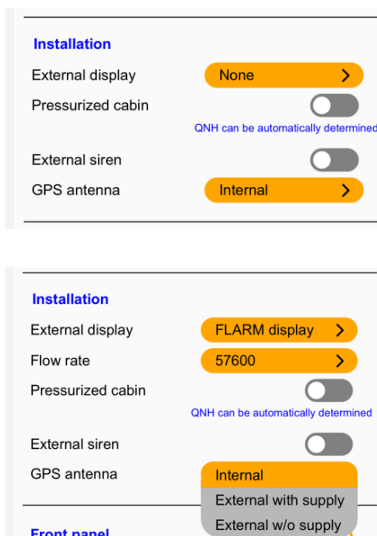

Depending on your installation within the device:

- If you are connecting a traffic display, choose FLARM display and select the transfer data rate as provided in your display specifications
- If your cabin is pressurized, check the box: be careful, your QNH can be calculated automatically only if you have a transponder.
- If connecting to an external siren, check the box.
- If you are connecting an external GPS antenna, select the correct choice from the list according to your antenna power supply.

6.5.8 Front

Here it is possible to disable and configure the display of the front panel of the **SuperNeurone**.

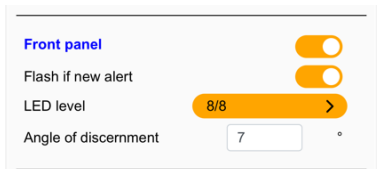

Flash if new alert: A powerful flash is activated once if a new alert is identified after a long time without notification, in order to arouse the pilot's attention.

The discernment angle allows the viewing angle to be configured on the front of the **SuperNeurone** in the event of a risk of collision. See Chapter 9 "**Usage**".

6.5.9 Audio



Set up sound alerts here:

- The yellow (proximity) alert can be deactivated here to avoid too frequent audible alerts.
- In the case of a voice card integrated into the **SuperNeurone**, the voice and language are configurable.

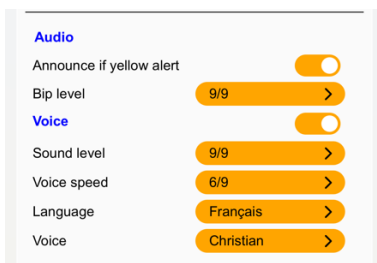

6.5.10 Options



Encryption is not to be used in standard mode.

Use simulation mode only to test your device. It will simulate the flight of 2 planes.

6.5.11 QNH

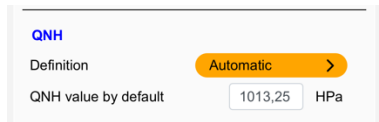

The QNH is an important piece of information: it is automatically detected unless the following conditions are met:

- Your cabin is pressurized.
- You don't have any transponder.

In this case, choose Manual mode and specify the value of QNH at each start.

6.5.12 Wi-Fi

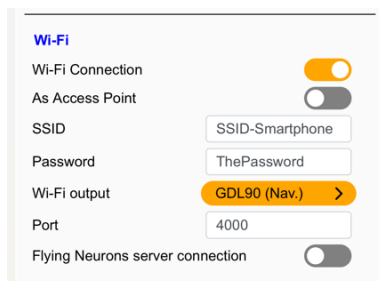

The **SuperNeurone** is equipped with Wi-Fi. There are two ways to connect:

- Connect to your smartphone network: do not activate the access point and enter the network information (name and password)
- Create a network where you connect your other devices: Activate as an access point, set the network name and password (**at least 8 characters and maximum 63**).

This Wi-Fi allows:

- Forwarding traffic and risk via GDL90 to your navigation application or EFIS.
 - o Choose GDL90 and port 4000 in general
- Forwarding our proprietary FLNO frames to a UDP or TCP server: Enter the server's IP address and port.
- Connecting to the Flying Neurons server in order to collect/transfer information via the internet.

6.5.13 My SuperNeurone

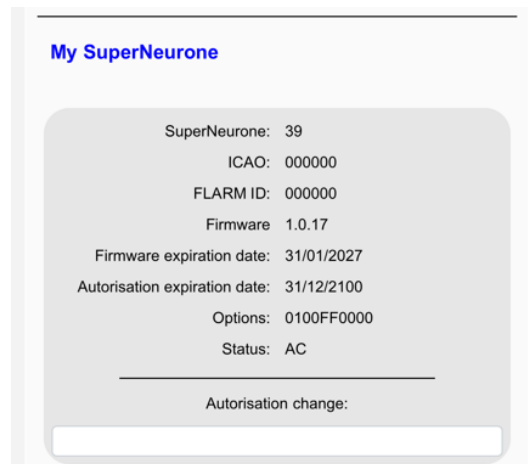

This last part of the screen informs you of the software version of the **SuperNeurone (Firmware)** as well as its **expiration date**. New versions are regularly made available automatically. It is advisable to download them because they improve the system or correct detected malfunctions.

The "**change of authorisation**" is reserved for future uses.

6.5.14 Validate and send the configuration to the SuperNeurone

Once your configuration is set, send it to the **SuperNeurone** by clicking on the flashing icon at the top right of the banner. The **SuperNeurone** will restart with this new configuration and reconnect after a few seconds to the **SuperNeuroFly App**.

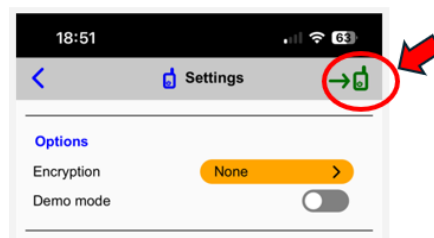

7 Configuring third-party instruments or software

7.1 Transponder

There are a maximum of 2 types of information to be provided to the transponder during its configuration. Some transponders require less.

- Activation of ADS-B-OUT. This consists of telling the transponder that a GPS position is sent to it on its serial input.
- Serial link rate. If the transponder allows multiple rates, the **SuperNeurone** uses the maximum rate.

7.2 Radio

You may need to enable the auxiliary input of the radio. Some radios also allow you to manage the priority between messages received by air and messages received on the auxiliary input. This ensures that you are not disturbed during conversations.

7.3 Display traffic

7.3.1 ATD from Air-Avionics

- Set the input protocol to "PowerFlarm".

7.4 Navigation software

Communication between the **SuperNeurone** and the navigation applications is done over Wi-Fi using the GDL90 protocol.

- The smartphone or tablet using the navigation software must be on the same Wi-Fi network as the **SuperNeurone**. You have 2 possibilities for this:
 - Set up your smartphone or tablet in hotspot and configure your **SuperNeurone** to connect to your smartphone or tablet.
 - Set your **SuperNeurone** to "Access point" and configure your smartphone or tablet to connect to your **SuperNeurone**.
- Then activate the GDL90 of the **SuperNeurone**, usually choosing port 4000 if requested.
- In the navigation App, also enable the GDL90 protocol and choose port 4000 if requested.

8 Update

The SuperNeurone's firmware is updated periodically and its installation on the **SuperNeurone** is done via the **SuperNeuroFly** App available on AppStore and GooglePlay.



If your smartphone or tablet is connected to the internet, the **SuperNeuroFly** App will automatically inform you as soon as you connect with your **SuperNeurone** if a new firmware version is available. **SuperNeuroFly** then offers you to update your **SuperNeurone** via the following dialog:

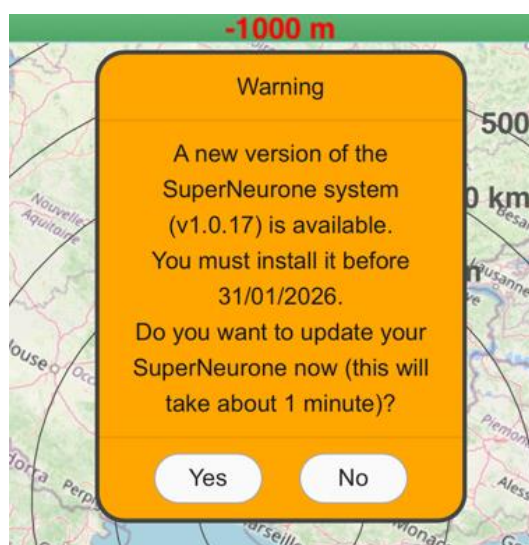

Click "Yes" and keep your **SuperNeurone** close to the phone. The update takes about 2 minutes.



During the SuperNeurone update, it is advisable not to call or use other applications on the smartphone or tablet performing the update. Similarly, do not move the smartphone or tablet away from the SuperNeurone.

If you want to update later, you can do so via the Advanced menu of the "**My SuperNeurone**" dialog.

If the update failed, it will be automatically re-offered to you the next time you connect to the **SuperNeurone**.

9 Usage

9.1 Starting and stopping

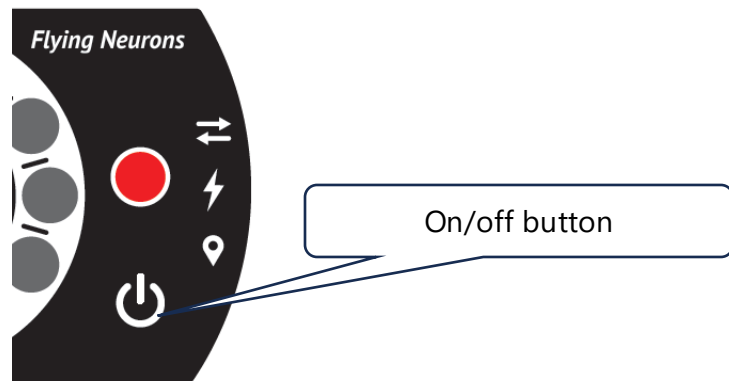

- Press the on/off button for 1 second to start the **SuperNeurone**.
- Press this button for 3 seconds to shut down the **SuperNeurone**.

It is possible to configure the **SuperNeurone** to start and stop automatically as it is in charge.

9.2 Front panel display

The **SuperNeurone** distinguishes 3 levels of risk:

- **Yellow risk**: an aircraft is in the potential danger zone, with no risk of collision.
- **Orange risk**: the future trajectory of an aircraft is close to yours.
- **Red risk**: proven risk of collision in the coming seconds.

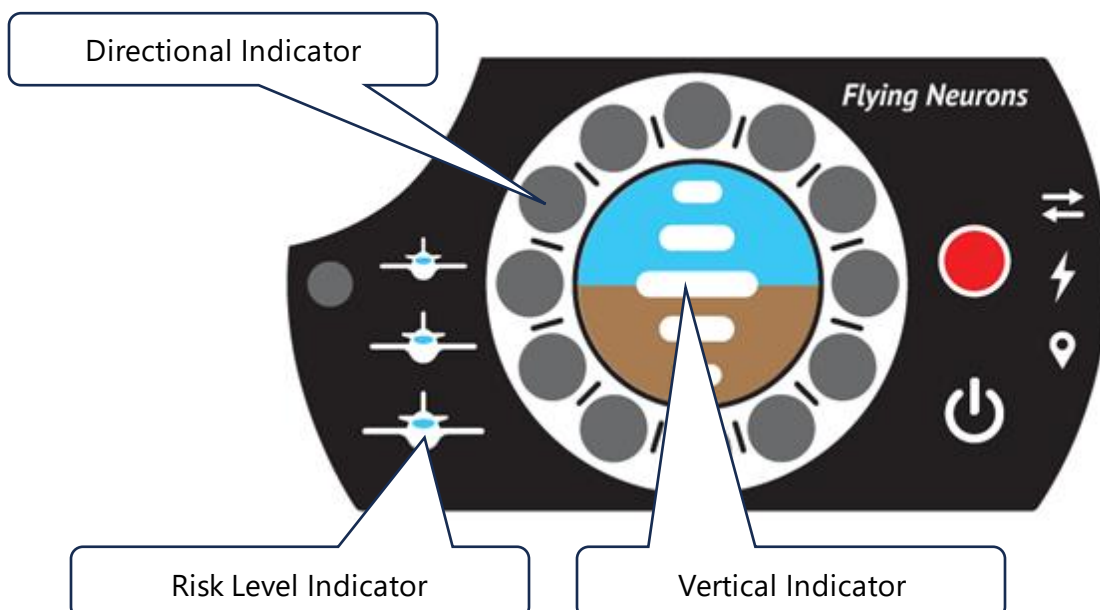

9.2.1 Directional Indicator

- Indicates the direction of the danger in the horizontal plane.
- Flashes yellow for a yellow danger.
- Flashes red slowly for an orange danger.
- Flashes red quickly for a red danger.

9.2.2 Risk Level Indicator

It lights up when one of the risks is detected and takes on the colour of the risk.

9.2.3 Vertical Indicator

It indicates **the angle of view**, which is the angle formed between the horizontal plane and the line from your aircraft to the dangerous aircraft.

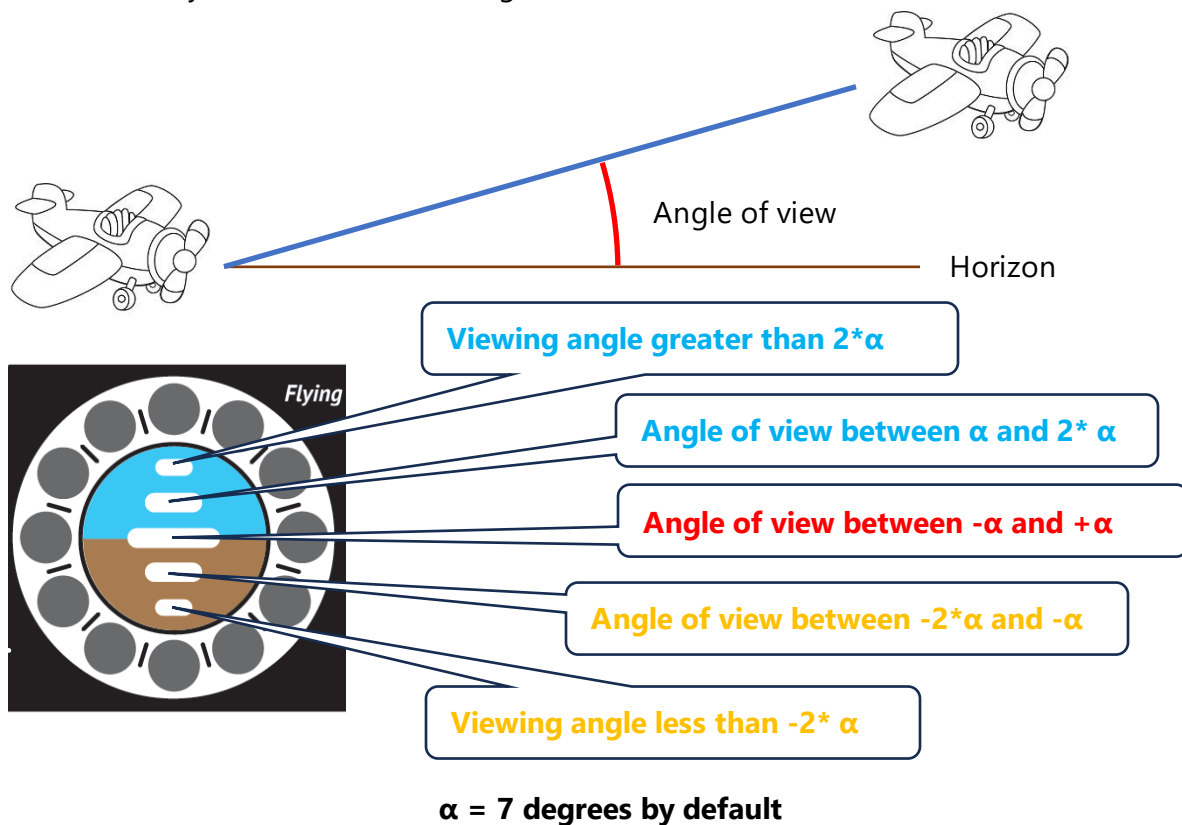

- The indicator is red if the dangerous aircraft is substantially in your horizon line.
- The indicator is blue if the dangerous aircraft is higher than you.
- The indicator is amber if the dangerous aircraft is below you.

The limit values of the viewing angle can be configured. The default value of α is 7 degrees. This is the “discernment angle” in the “front” menu.

9.2.4 Special case of "Mode S"

Mode S transponders communicate the aircraft's altitude but not its position. It is therefore not possible for the **SuperNeurone** to display a direction of danger.

The **SuperNeurone** then displays the danger as follows:

- 4 yellow flashing leds on the directional indicator.
- Yellow risk level indicator.
- Vertical indicator according to altitude difference **dA**.

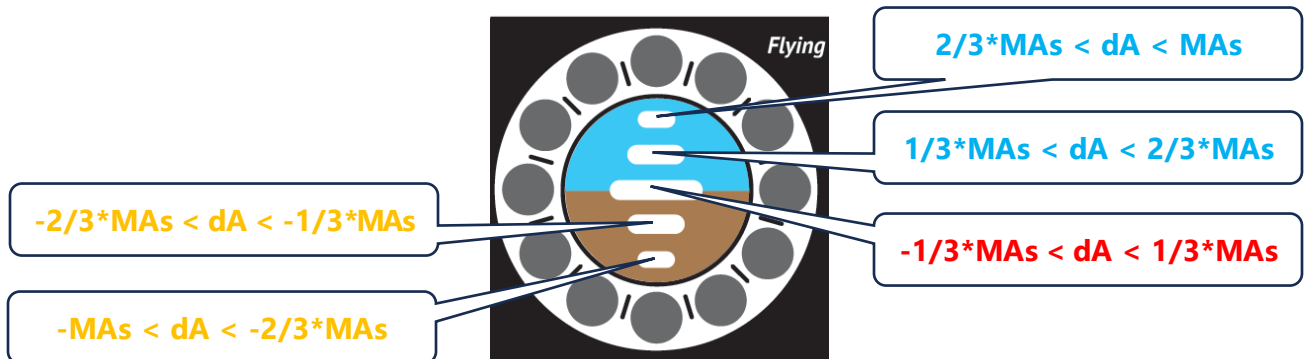
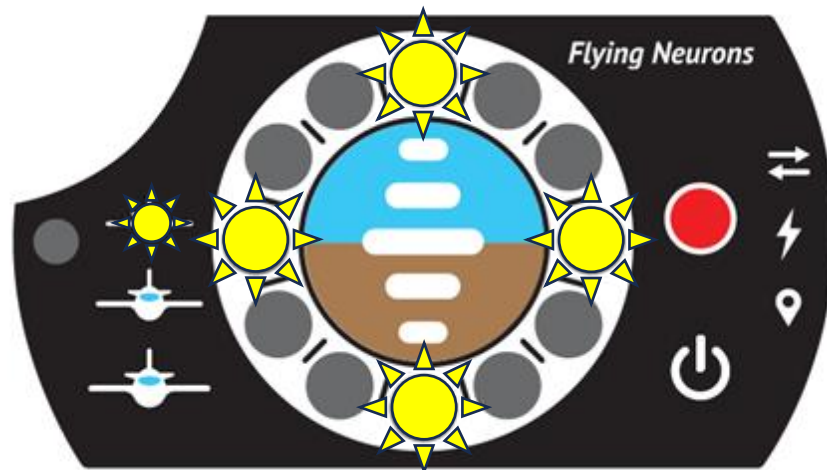

- **dA**: relative altitude of the aircraft emitting mode S.
- **MA**s: Maximum altitude difference set for Mode S alerts.

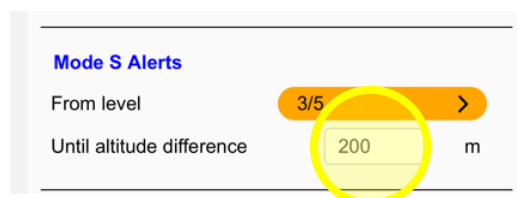

9.2.5 Status Indicators

These 3 indicators make it possible to check the proper functioning of the **SuperNeurone**.

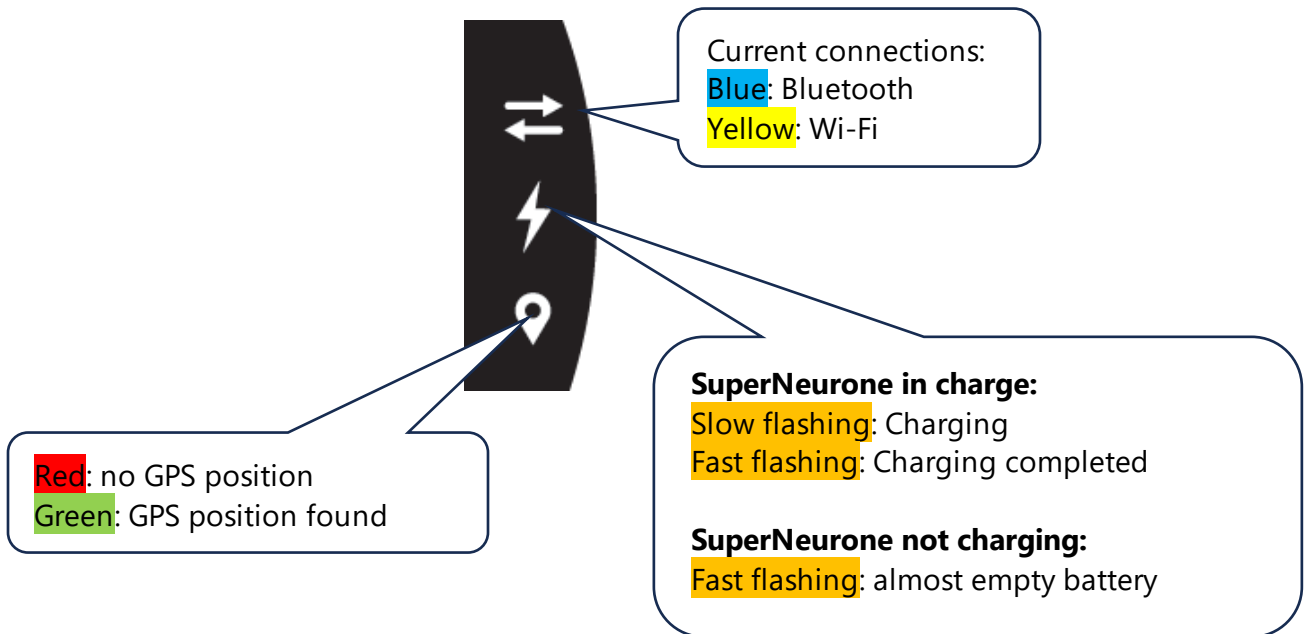

9.3 Using SuperNeuroFly to Visualize Traffic and Risk

SuperNeuroFly is our application that allows you to:

- **Configure the SuperNeurone** – see Chapter 6 "**SuperNeurone Configuration**"
- **Update the SuperNeurone** – see Chapter 8 "**Update**"
- **Visualize traffic and risks:** this is the feature detailed here. This is an option: you can either simply use the **SuperNeurone** front display or another traffic display.

SuperNeuroFly is available on AppStore and GooglePlay.



9.3.1 Standard operation

Configure the display and sound announcements to your liking before starting the flight (see the chapter below "**Configuring the App**").

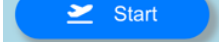
For the first time, press the button  to connect to your **SuperNeurone**, then click on it in the list to connect:

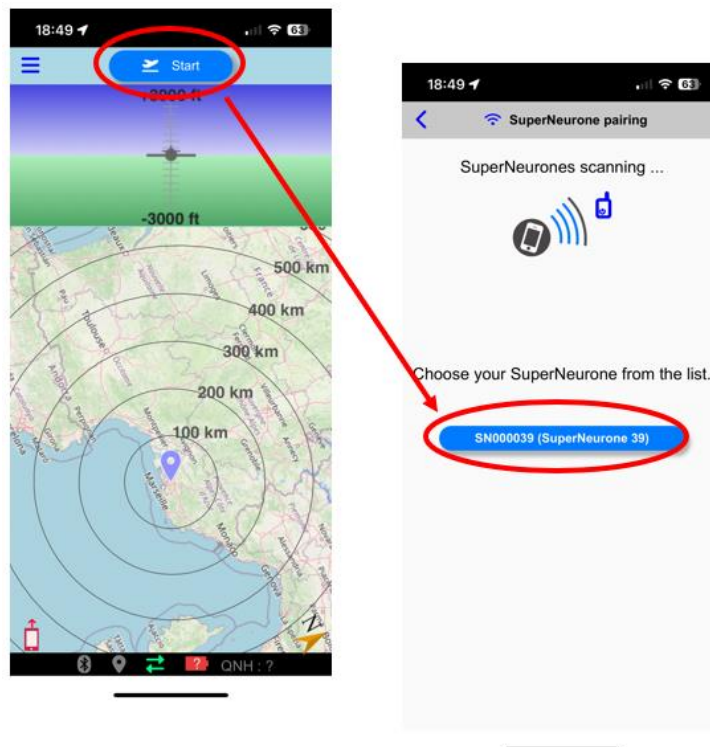

Note that the next time the application is started, **SuperNeuroFly** will try to connect immediately to the last **SuperNeurone** used.

A voice announces the start of the flight: if no voice is heard, then check the volume of your phone, the connection to your headset or change your voice in the "**App Configuration**".

During the flight, if no risk is identified and if the operation is correct, the thumbs up is displayed in the banner and **SuperNeuroFly** remains silent. Your location and the surrounding traffic are displayed on the map.



If a fault is detected, an audible message informs the driver and the banner passes in malfunction mode.



If a risk is detected, a visual and audible alert is lifted; A cone is displayed on the screen and the banner contains the information.

You can place the application in the background if you wish: it will continue to work and warn you if necessary, with an audio message.

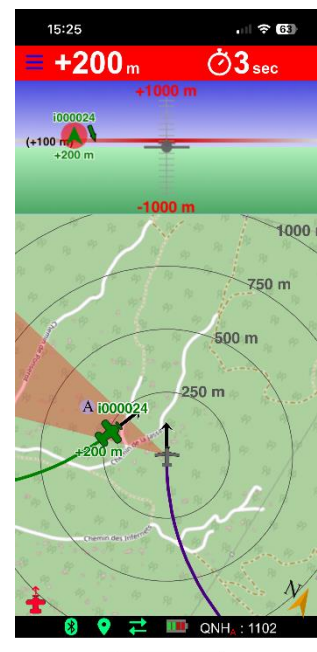

At the end of the flight, press the "Stop" button in the menu.

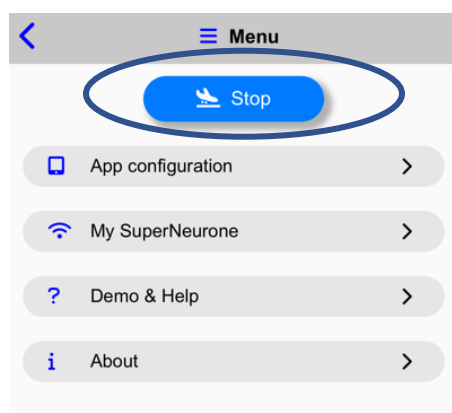

9.3.2 The main screen

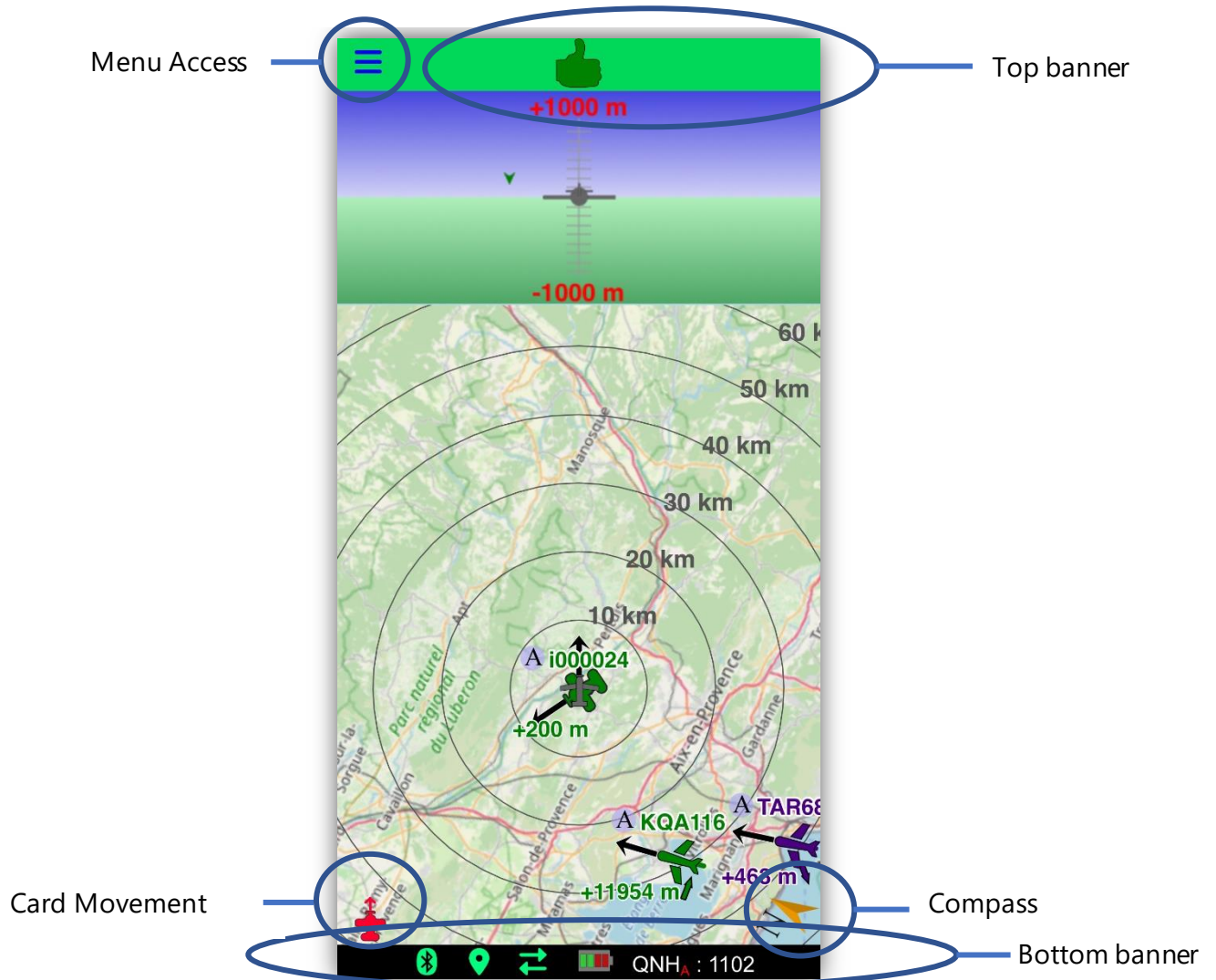

9.3.3 The top banner: The main information

This banner summarizes the main information for the user. The order of priority is that of the presentation of the following different information, from the least important to the most important:

- **Pending – not connected:**



- o On a blue background with the "Start" button.
- o In this mode, no traffic is retrieved, and no risk analysis is performed.

- **Normal operation, with no known dangers:**



- In a green background with a thumbs up, the flight is underway, the system is operational, and no risk is identified.

- **System Failure or Malfunction:**



- The yellow key is displayed on a black background, in case of detection of a failure of a system element (loss of GPS signal, loss of connection, etc.). Click on it to get the more precise information (an audible alert is also made when the fault is discovered).

- **Danger identified:**









- The most important of the detected dangers is displayed with the colour and information depending on the height and nature of the risk (yellow, orange, red or grey). See Chapter 9.2 for more details.



9.3.4 The bottom banner: the status of connections and peripherals

The bottom banner displays the status of the main elements of the system:

- **Bluetooth pairing with a SuperNeurone:**



-  Grey: No **SuperNeurone** connected, but no flight is in progress: normal waiting situation.
-  Red: No **SuperNeurone** paired while a flight with **SuperNeurone** is in progress. So, there is a problem with the Bluetooth connection.
-  Green: Connected **SuperNeurone** .
-  Orange: Connection with a **SuperNeurone** in progress.

- **GPS Position:** This is the GPS position of the **SuperNeurone**. The **SuperNeurone** outside can take about a minute to position itself when it is turned on.
 -  Grey: no flight in progress, the **SuperNeurone** GPS is not recovered: normal waiting situation.
 -  Red: The connected **SuperNeurone** has no GPS position
 -  Green: The **SuperNeurone** has a precise GPS position.

- **Telephone network connection:** the exchange arrow indicates **SuperNeuroFly's** connection to the GSM network and therefore to our servers.
 -  Green: The connection to our server is established. You retrieve the positions of the aircraft via the OGN network (FLARM, OGN trackers, SafeSky or PilotAware) and, during the flight, your position is exchanged in real time.
 -  Red: there is no connection to the server (no telephone network or WI-FI connection). You don't receive any position from the OGN network nor provide yours in real-time. Also note that the basemap is not updated if the connection is lost

Note: The lack of a network does not prevent **SuperNeuroFly** from working **with** the **SuperNeurone** (**SuperNeurone** connection, detection, alerts).

SuperNeuroFly is constantly trying to connect to the network and retrieves it without any action on your part as soon as possible. The temporary loss is usually due to a "white" area of the GSM network.

- **Battery**  : This is the charge level of the **SuperNeurone**. The lightning bolt  indicates it is connected to the power.

- **QNH:** The current value of the QNH (in Hpa) is indicated once connected to the **SuperNeurone**. The A (Automatic) or M (Manual) index indicates the definition mode as configured in the **SuperNeurone**.

9.3.5 The menu and dialogues

Access to the menu is via the button  at the top left of the screen.

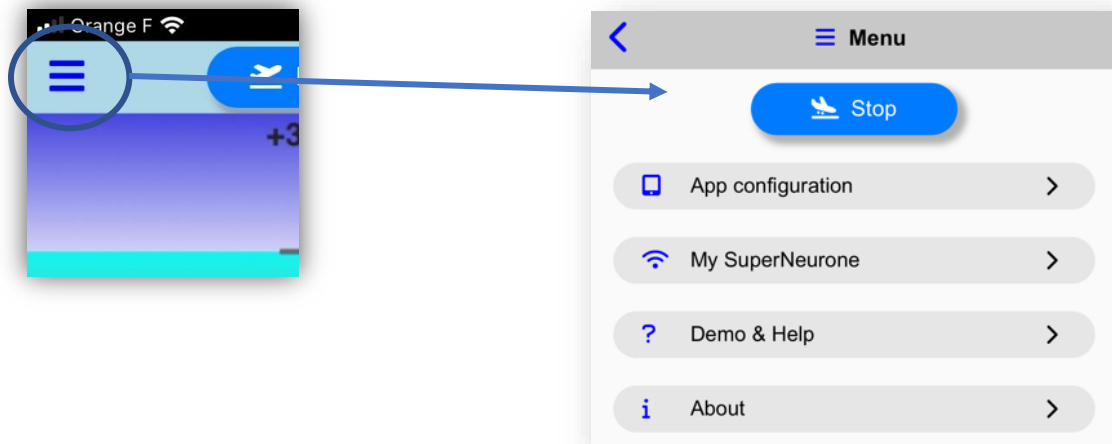

The different dialogs available in this menu are described in the following chapters of this manual. Use the key  in the top left to go back.

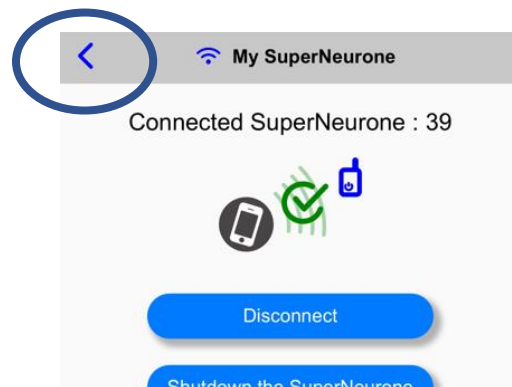

9.3.6 The map

The map allows you to visualize your position and that of the aircraft near you.

The content of the map depends on your configuration choices.









- **Your aircraft:**
 - When your **SuperNeurone** has a GPS position, it is displayed in grey (with the symbol corresponding to your aircraft type) in the center of the circles (radar style centred on you).









- **Distance circles:**
 - They are centred on the connected **SuperNeurone** and adapt to the zoom level. Their unit is defined in the **SuperNeurone** configuration.
- **The orientation of the map:**
 - The direction of North is displayed at the bottom right of the map.



- **Other aircraft:**
 - If the aircraft is on the ground, it is displayed via an icon corresponding to the aircraft type in "transparency". 
 - If the aircraft is not on the ground, its display depends on your configuration (see the chapter "**App Configuration**").



- The icon depends on the display configuration:
 - In TCAS mode, aircraft are symbolized by an arrow and a frame depending on the level of risk:
 -  No risk, distant aircraft
 -  No risk, aircraft close
 -  Yellow risk
 -  Orange risk
 -  Red risk
 - Outside of TCAS mode, corresponds to the type of aircraft, for example:
 - 
 - 
 - 
 The colour is random (fixed by the aircraft identifier) in order to easily differentiate between aircraft.

- a label is written above, if not deactivated in the configuration (see the chapter "**App Configuration**"). This label contains:
 - An icon describing the source of the position:
 -  Neuron or **SuperNeurone** received directly by your **SuperNeurone**.
 -  : ADS-B received live by your **SuperNeurone**.
 -  : FLARM received live by your **SuperNeurone**.
 -       (symbol in a cloud) **SuperNeurone**, ADS-B, FLARM, OGN tracker, SafeSky and PilotAware received **via the telephone network**.

- The aircraft identifier:
 - The name or registration of the aircraft if retrieved by the **SuperNeurone**. Otherwise, its ICAO number (preceded by i) or address (FLARM, SafeSky) or its **SuperNeurone** ID (if the pilot has decided to remain private, a temporary ID with a question mark is displayed).

- The altitude of the aircraft or its altitude relative to your aircraft (positive if it is above you). The unit (meter or feet or flight level difference FL) is defined in the "**App Configuration**". If so, an arrow indicates the climb or descent of the aircraft.



- If requested in configuration, the direction of travel of the aircraft is indicated by an arrow.
- A route representing the last 2 minutes of the aircraft positions (in the colour of the aircraft) is also optionally displayed.

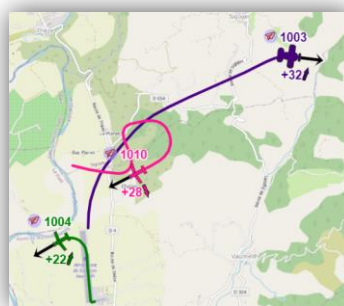

- **Aircraft Details:**

- By clicking on an aircraft, detailed information is displayed. Click on the information panel itself to make it disappear.

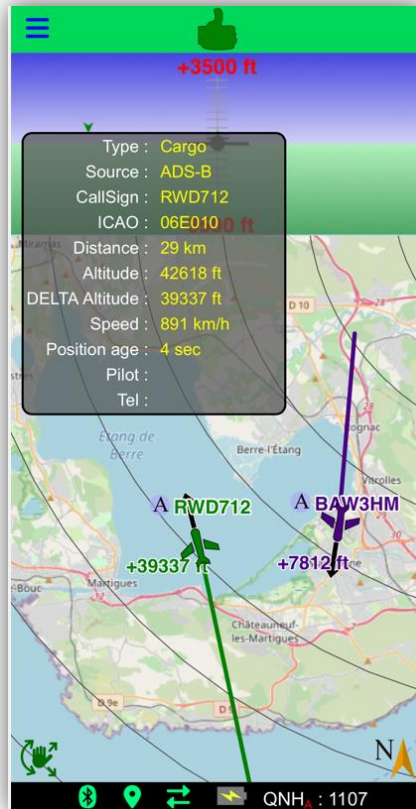

- **Map Movements:**

Depending on the choice with the "Card Movement" button, the interactive and automatic card movements are different:

- **Translation and Rotation:**



- **"On board" mode (default):**

- If a **SuperNeurone** is connected and has a GPS position:
 - the map is centred on the position of the **SuperNeurone**.
 - the map is oriented in the direction of the **SuperNeurone's** movement. If the **SuperNeurone** is at low speed, the map is facing the direction of the phone
 - If no **SuperNeurone** is connected or does not have a GPS position:
 - the map is centred on the position of the Smartphone.
 - The map is oriented in the direction of the Smartphone.



"North" mode:

- As with the onboard mode, the map is centred on the position of the **SuperNeurone**.
- The orientation of the map is fixed on the other hand, and North is at the top, regardless of the orientation or movement of the **SuperNeurone**.



"Manual" mode:

- The card can be moved by swiping a finger or rotated by rotating 2 fingers on the card.
- The map defaults to north when switching to manual mode.
- It is possible to put the map back with the North at the top by clicking on the "compass" at the bottom right of the screen.

○ **Zoom:**

- An automatic zoom mode exists (see the chapter "**App Configuration**"); it adapts the zoom of the map according to the dangers (to make them clearly visible) and a default distance in the absence of danger. It is only active in "Onboard" or "North" mode.
- In any case, it is possible to zoom in by pinching the map with 2 fingers. If auto zoom is enabled, it will take over after a few seconds.

9.3.7 The artificial horizon

The "yellow" risk aircraft:

Left, behind (7H)

300 feet below

Downhill

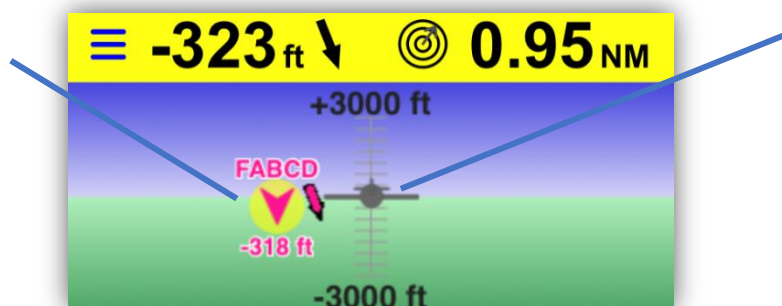

Your Aircraft

Its display is optional, and its display can be configured via the horizon/map ratio in the "**App Configuration**" dialog (see the « **App Configuration** " chapter).

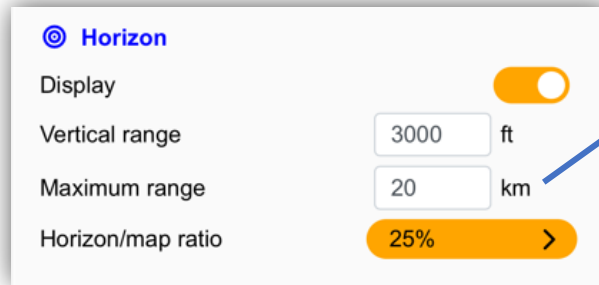



Only aircraft located at a shorter distance are displayed.

It represents the view from the **SuperNeurone** and allows you to visually see the relative position of other aircraft.

Your aircraft is symbolized in the center, the blue area is above you and the green area below.

- **Display of aircraft with known position (SuperNeurone, ADS-B, FLARM, SafeSky,...)**

Positioned aircraft detected within the surveillance range and located in the altitude range and at a distance less than the maximum range of the horizon are displayed on the display with a symbol:

- **Right or Left:** The symbol is positioned to the right or left depending on where it is located in relation to your direction of movement (straight ahead).
 - The extreme edge of the screen corresponds to 90° (3 o'clock on the right and 9 o'clock on the left).
- **Ahead or behind:** The symbol points up if it is in front of you, but it is turned over (pointing down) if the aircraft is behind you.
- **With a symbol** depending on the configuration chosen (TCAS display mode or not) and the risk:
 - Aircraft are symbolized by an arrow of the colour assigned to the aircraft by **SuperNeuroFly** on the map, such as. 
 - Their (vertical) trend is displayed by an arrow. 
 - If the aircraft is the one identified as the most at risk, it is highlighted by a dot in the colour of the risk. Its identification and altitude (relative, depending on the configuration) are also displayed.
 - If the aircraft is behind you, the arrow is pointing downwards, such as 

- **Mode S Display**

Aircraft equipped with Mode S and received by your **SuperNeurone** are displayed in the artificial horizon. The only information being their altitude and signal strength, these aircraft are represented by a band across the entire width of the horizon, placed at their altitude and grey in colour in case of safety.

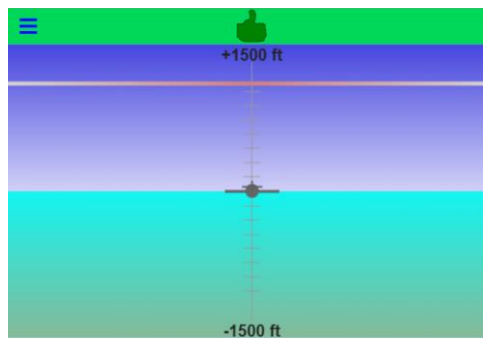

Risk-free S mode

The colour of the band is more or less red depending on the power level (out of 5). If the risk is significant (greater than or equal to that defined in the configuration – default 2/5), the identification number and altitude are written on the band (see the chapter "risks" below).

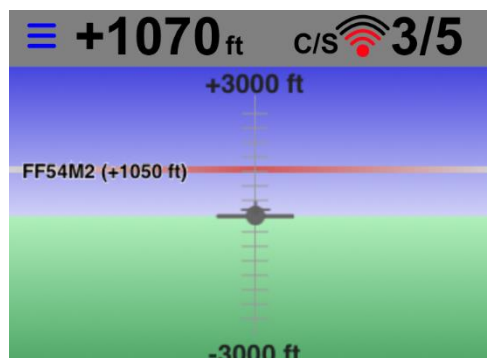

S mode in risk 3/5

It is possible to zoom in on the horizon as well as on the map by pinching with two fingers. If the automatic zoom mode has been chosen, the horizon returns to its preset altitude range in the "**App Configuration**" after a few seconds.



9.3.8 Collision risks, visual and audible alerts

The goal of **SuperNeuroFly** is to warn you of the collision risks determined by the **SuperNeurone**. The risks are categorized, involving different reactions on the part of the pilot. The alert modes are visual and audible in order to transmit the information to the pilot as well as possible.

2 risk restitution modes are implemented depending on whether the detected aircraft provides its position (via a SuperNeurone, FLARM, ADS-B, SafeSky, PilotAware transmission, etc.) or not (via a Mode S transponder transmission).

9.3.8.1 **The aircraft whose position is known (SuperNeurone, ADS-B, FLARM, SafeSky or PilotAware)**

Visual alerts:

- **The top band is the color of risk.**
 - The information displayed is:
 - The altitude difference.
 - The vertical direction of movement of the other aircraft.
 - Distance (yellow or orange risk) or time to impact (red risk).
- A flashing yellow (or orange or red) cone is displayed on the map. He points the direction of the danger.
- **The zoom adapts** (in auto mode) to see the dangerous aircraft well.
- **a yellow (or orange or red) circle is displayed below the dangerous aircraft** on the artificial horizon (where the aircraft is represented by ,  or  in TCAS mode).

Example of a red alert:

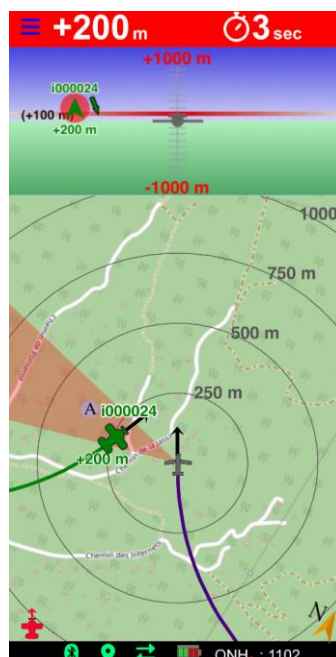

Audible alerts:

- A **short "yellow traffic"** alert (or orange or red) is repeated frequently (can be deactivated, see the chapter "**App Configuration**").
- A **detailed alert** such as "**yellow traffic, light aircraft, 3 hours, 500 feet down, 2 nautical miles**" is announced when this danger appears and every 20 seconds (configurable, see the chapter "**App Configuration**").

Remarks:

- *the audible alert is triggered even if **SuperNeuroFly** is in the background.*
- *In the case of multiple risks, only the most dangerous risk (in level, then in potential impact time in the event of several aircraft having the same level of risk) is taken into account for visual (cone) and audible alerts.*

9.3.8.2 The nearby aircraft is an aircraft equipped with a Mode S transponder:

The positions of aircraft equipped with Mode S transponders are not known. Indeed, they only provide their altitude. However, the **SuperNeurone** also measures the power of the emission received, which makes it possible to estimate the relative distance from the aircraft.

Thus, a risk is calculated, based on the difference in altitude and power (0/5 to 5/5).

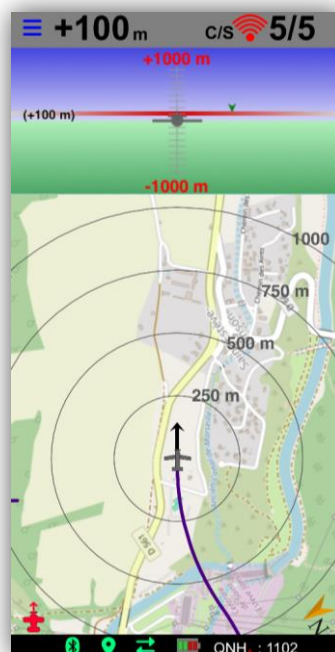

Visual alerts:

- **The top band is on a grey background** and displays the difference in altitude and the level of power.
- In the artificial horizon, **the band located at the altitude of the aircraft is displayed with a more or less red tone** depending on the power level.
- In the artificial horizon, **the aircraft's identification and altitude differential (or altitude depending on your configuration) is recorded.**

Audible alerts:

- The detailed alert such as "**traffic Mode S, 100 feet down, power 4/5**" is announced when this danger appears and every 20 seconds (configurable in configuration).

9.3.8.3 No aircraft are identified as dangerous

In the event that no aircraft is dangerous (aircraft with position or in Mode S), then **SuperNeuroFly** is silent and informs you of this nominal situation with the thumbs up on the green banner:

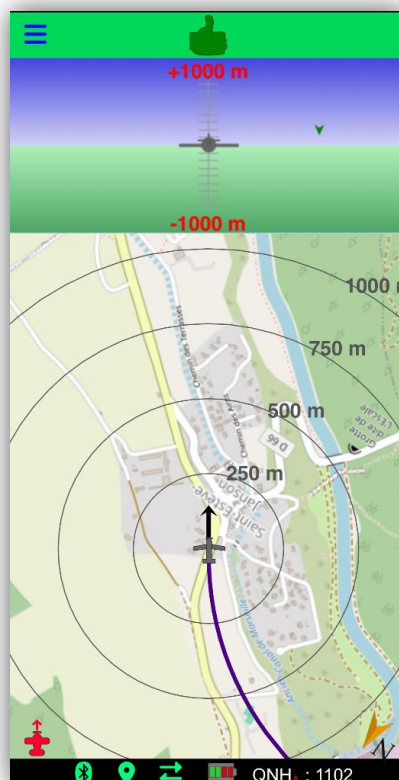

9.3.9 My SuperNeurone

You have access to pairing, disconnecting, and shutting down the **SuperNeurone** in the "**My SuperNeurone**" dialog.

In this dialog, you also have access to the **SuperNeurone** configuration (once connected) and the advanced actions of the **SuperNeurone**.

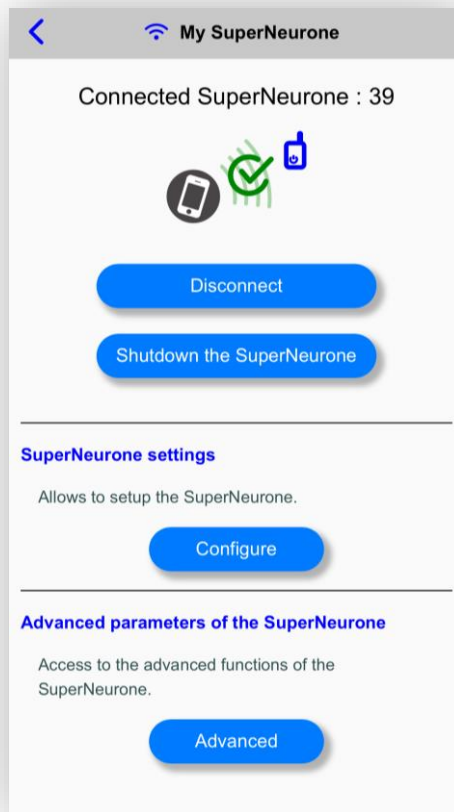

SuperNeurone

Pairing/Disconnection

Connected
SuperNeurone
configuration

Access to the
SuperNeurone
update and
advanced
features.

9.3.9.1 SuperNeurone Setup

See Chapter 6 "**SuperNeurone Configuration**".

9.3.9.2 Advanced features

In the "Advanced" dialog you have access to some specific features of the **SuperNeurone**:

Firmware update

See Chapter 8 "**Update**".

Resetting the SuperNeurone configuration

This feature allows the configuration values of the **SuperNeurone** to be reset to its default values.

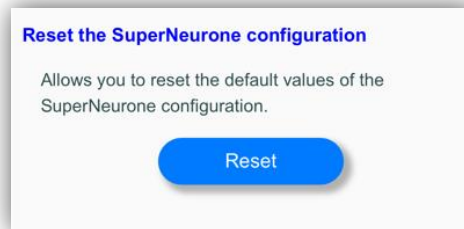

9.3.10 App configuration

This very important dialog allows you to configure the whole of **SuperNeuroFly**:

9.3.10.1 Horizon

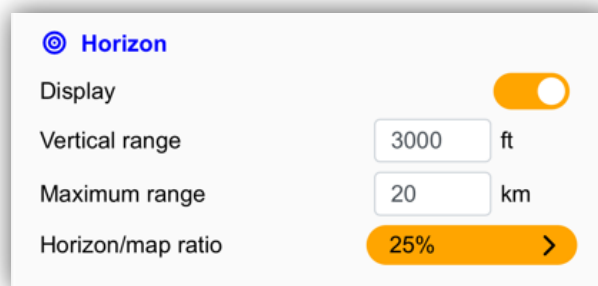

This section concerns the actual display of the artificial horizon:

By unchecking "**Display**", the artificial horizon is not displayed and only the map is on the screen. Note that the S Modes will not be "viewable" but the alerts concerning them are still activated.

The "**vertical range**" corresponding to the min and max altitude difference displayed by default. You can zoom in and out manually by pinching with two fingers into the artificial horizon. If the "**Auto Zoom**" mode is activated (see below) then the artificial horizon gradually returns to the default range set here after a few seconds.

The "**maximum range**" allows you to filter and not show aircraft far from you in the horizon. A high value will pollute the display: it is interesting to limit it to, for example, 30 km so as not to have too many aircrafts on the horizon. Note that planes far away are displayed with a discrete symbol: 

The "**Horizon/map**" ratio allows you to change the part of the screen used by the artificial horizon.

9.3.10.2 Display



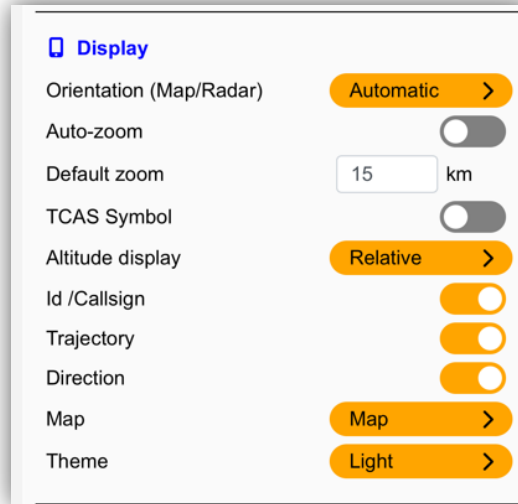

Use this topic to configure the display of the map and the artificial horizon:



- **Orientation (Map/Radar):** Allows you to control the orientation of the display on a smartphone:
 - o **Automatic (default):** the map and menus will adapt to the position of your phone.
 - o **Portrait:** The app will be displayed in portrait mode, even if the smartphone is oriented in landscape mode.
 - o **Landscape:** The app will be displayed in landscape mode, even if the smartphone is oriented in portrait mode.

- **Auto Zoom:** If checked, the map zoom automatically adjusts based on the nearest danger. Thus, a zoom is made in order to keep this risk at about half a screen width to make it clearly visible.
Similarly, if you (de)zoom out the map by pinching with 2 fingers, the zoom returns to its default value or to the value imposed by the danger after a few seconds.

- **Default zoom:** this is the initial zoom which is also the zoom value in the "**Auto Zoom**" mode when there is no danger.

- **"TCAS Symbols Display":** by activating the option, the aircraft symbols in the map and the artificial horizon are the TCAS symbols ( ,  ,  ,  , see the paragraph "**the map**" for their meaning). Otherwise, the symbols are representations of the type of aircraft such as:



- **Altitude Display:** There are three modes available to display the altitude under the aircraft symbol:
 - o **"Absolute"** altitude: The altitude displayed is the GPS altitude of the aircraft in relation to sea level. The unit is the one defined in the **SuperNeurone**.
 - o **"Relative"** Altitude: The altitude displayed is the difference in altitude between you and the aircraft. The value is negative if it is below you. The unit is the one defined in the **SuperNeurone** configuration.
 - o **"FL difference"**: the displayed altitude is the difference in flight level (TCAS style) expressed in hundreds of feet: thus +47 means that the aircraft is 4700 feet above you.
 - Note that in case of **"FL Difference"** the audible announcement does use the unit of height defined here.

- **Trajectory:** If active, the aircraft path over the last 2 minutes is displayed.

- **Direction:** If active, an arrow indicating the direction of movement of the aircraft is displayed.

- **Background map:**
 - o Several possibilities are available:
 - Map: A map is displayed.
 - Satellite: A satellite view is displayed.
 - Clear: A bright background is displayed, allowing better visibility in bright light.
 - Dark: A dark background is displayed, allowing for better visibility in high/low light.



9.3.10.3 Language

Here you can define the language used in the display and audio announcements.



9.3.10.4 Audio

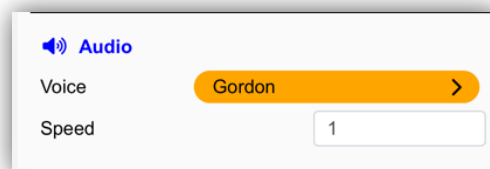

This topic lets you choose the voice used in the audio announcements and the speed at which the voice speaks.

If no voices are heard when starting the flight or when choosing from the list of voices provided, change your voice, the voices may not be downloaded to your smartphone. You can update your smartphone's voices in the smartphone's settings (under Accessibility > Spoken Content > Voice > English on iOS and under Accessibility > Text-to-Speech on Android).

9.3.10.5 Audio Alerts

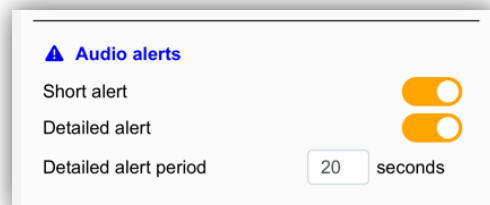

Use this topic to configure **SuperNeuroFly's** sound alerts. There are 2 types of alerts:

- **The brief alert** (e.g. "Orange traffic") is frequently announced every 5 or 7 seconds depending on the alert level. It can be deactivated here.
- **The detailed alert** is longer and specifies type, heading, height and distance (e.g. "red traffic, helicopter, at 2 hours, 200 feet down, 400 meters") or power height for S modes

("Traffic S, 300 feet up, power 3/5"). It can be skipped here, and you can set the time interval between these messages. Note that the detailed alert is restarted before the end of the period if the danger rises in level or changes aircraft.

For example, you can disable the brief alert and set the interval to 40 seconds to have a less intrusive application.

9.3.11 Demo / Help

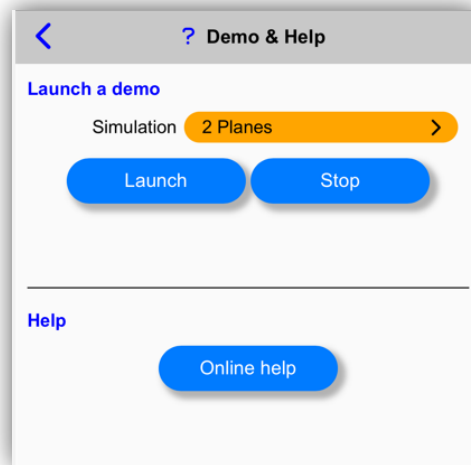

Use this dialog to launch demos without a connection to the **SuperNeurone**:

- The "2 Planes" demo simulates the flight of a light aircraft with convergence with another light aircraft. It allows you to understand visual and audible alarms (which you can configure in your own way in the "App Configuration" dialog).
- The "3 Planes" demo simulates the flight of a light aircraft with the presence of 2 other aircrafts.
- The "Airplane and Mode S" demo simulates the flight of a light aircraft (equipped with a **SuperNeurone**) with the presence of another aircraft equipped with a Mode S.

Any flight in progress will be stopped and the demo flight will start as soon as you press "**Launch**".

The "**Online Help**" button takes you to our [Help Center](https://www.flyingneurons.com/site) on our <https://www.flyingneurons.com/site> , where you will find our manuals and our list of questions and answers (FAQs).

9.4 Other Display Devices

9.4.1 Display traffic

The **SuperNeurone** can be connected via RS232 to any type of traffic display. Refer to the instructions for these devices to understand their use.

9.4.2 Navigation apps

The **SuperNeurone** can send all traffic information to common Wi-Fi navigation applications using the GDL90 protocol.

10 Errors and Failures

The **SuperNeurone** continuously tests its proper functioning and communicates any errors or failures to the user.

10.1 Failures displayed on the front panel

- Low battery voltage: The orange battery icon flashes very quickly.

10.2 Failures communicated to SuperNeuroSky

An error message is displayed on the screen.

11 Technical specifications

Size	80*63*32 mm
Weight	115 grams
Antennas	4 SMA connectors <ul style="list-style-type: none"> • ADS-B_IN • FLARM IN/OUT • NEURONE/ADS-L IN/OUT • GNSS Internal GNSS antenna
Radio traffic receivers	ADS-B, FLARM, NEURON/ADS-L
Radio traffic transmitters	ADS-B (via transponder), FLARM, NEURONE/ADS-L
Connections	RS232 , Serial Port, Wi-Fi , Bluetooth LE
Autonomy	10 hours
Load	5V USB or 6-32V on the extension connector. 1 A maximum
Expansion Connector	2 RS232, audio, charging, siren, GPIO
Interfaces	Bluetooth, Wi-Fi, GDL90, RS232
GNSS	GPS, GLONASS, BEIDOU, GALILEO
Sensors	Accelerometer, Compass, Pressure, Temperature
Voice	Mono Language: English or French (with optional voice module)